

Air Hammer

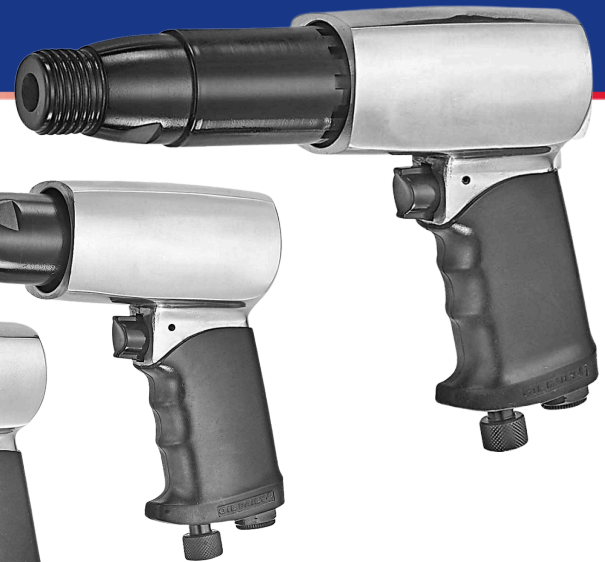

Features

- Durable, heavy-duty construction ideal for chipping, cutting, and peeling
- Quick changes (Spring Retainer, Old Type retainer, New Patent Retainer ALL available)
- Good Durability and Material Quality
- 150mm: SHORT AIR HAMMER
190mm: MED. DUTY AIR HAMMER
250mm: HEAVY DUTY AIR HAMMER

Needle Scaler Accessories Attached to Air Hammers/ Air Chisels



RECOMMENDED

PRESS HERE

NEW PATENT Retainer

Efficient & Easier!

**Easier to push down
Change chisels very fast**

Quick Changes ALL Type Available



Spring Retainer
Traditional One
Change slowly



Regular Retainer
Needs a strong push down

Tool Specifications

	BPM	Air Pressure	Air Inlet	Shank Opening	Stroke	Sound Pressure Level	Sound Power Level	Overall Length	Net Weight
150mm	4800	90psi	1/4"	0.401"	1-5/8"(41mm)	100 dB	110 dB	138MM	1.28 KG
190mm	3200	90psi	1/4"	0.401"	2-5/8"(66mm)	--	--	181MM	1.66 KG
250mm	2200	90psi	1/4"	0.401"	3-7/8"(98mm)	--	--	225MM	2.0 KG

APACH INDUSTRIAL CO., LTD.

176 Industrial 9th Rd., Tali Dist., Taichung City, Taiwan 41208
Tel +886 4 2271 2835 Fax +886 4 2271 4840
www.apach-tools.com info@apach.com.tw

