

**APACH**<sup>®</sup>  
BUILDING FUTURES



**APACH**<sup>®</sup>  
BUILDING FUTURES



2022.07

**APACH INDUSTRIAL CO., LTD.**  
176 Industrial 9th Rd., Tali Dist.,  
Taichung City, Taiwan 41280  
Tel +886 4 2491 5576  
Fax +886 4 2491 5580  
[www.apach-tools.com](http://www.apach-tools.com)



**DISTRIBUTOR**

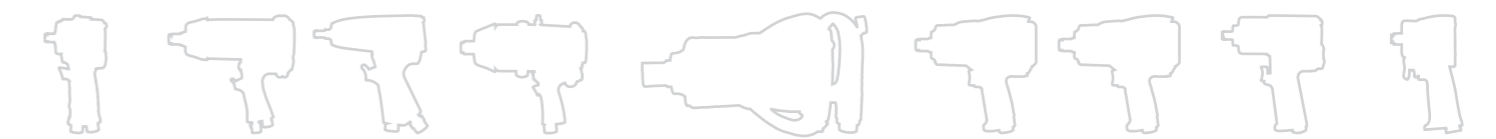
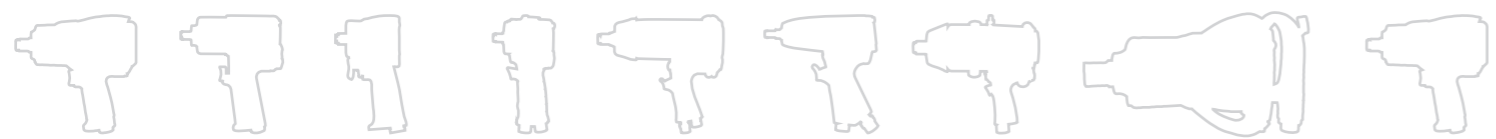

# FOCUS! CORE! BUILDING FUTURES!

Apach Industrial's humble beginnings began in 1993 in Taichung, Taiwan known worldwide for its machining and tool making prowess. Superior technology in metals and CNC machining in conjunction with a strong Taiwanese supply base made this area thrive with quality manufacturers of pneumatic and power tools. To this day the world's top name brands still build their high value quality tools here in Taiwan.

Therefore, APACH exquisitely designs each of its air impact wrenches, and insists on strict durability testing of every piece of key components and parts, as well as rigid pre-delivery inspections of finished products. Just like Apache Indians who are physically strong and capable, APACH's products are durable and can endure under harsh working environments; hence APACH is highly recognized and sought-after by professionals worldwide. Today, APACH is a globally known brand.

APACH offers a complete product line to solve customers' problems, including all series of air impact wrench, air sander, air screwdriver, other pneumatic tools and so forth which are ideal for use in industry, automotive, motorcycle, workshop, agriculture machine and boat. With a powerful R&D team and a wealth of collaborating experience with international brands, the company can customize or develop special-purpose tools tailored to OEM and ODM requests. Apach also collects client feedback and seeks to manufacture products that better fit the needs of users.

APACH's website "www.apach-tools.com" also provides further product information.

Underpinned by strong commitment to innovation and learning, as well as esprit de corps, APACH continues to launch new products to meet customers' special requirements, pays close attention to each customer's opinions, and provides speedy, timely services to clients. This globally prestigious brand is trustworthy.



## Common Applications



Motorcycle



Automotive



Truck



Agriculture Machine



Boat



Structure, Railway



Industry, Assembling Line

## CONTENT

◦ 新產品	<i>New Products</i>	<b>1</b>
◦ 氣動扳手	<i>Air Impact Wrench</i>	<b>3</b>
◦ 氣動起子	<i>Air Screwdriver</i>	<b>13</b>
◦ 氣動棘輪扳手	<i>Air Ratchet Wrench</i>	<b>15</b>
◦ 氣動刻模機	<i>Air Die Grinder</i>	<b>17</b>
◦ 氣動角度刻模機	<i>Air Angle Grinder</i>	<b>19</b>
◦ 氣動鋸	<i>Air Saw</i>	<b>20</b>
◦ 氣動砂光機	<i>Air Orbital Sander</i>	<b>21</b>
◦ 氣動噴槍	<i>Air Spray Gun</i>	<b>23</b>
◦ 氣動吹塵槍	<i>Air Blow Gun</i>	<b>29</b>
◦ 氣動鉚釘機/拉帽機	<i>Air Hydraulic Riveter/Nut Tools</i>	<b>31</b>
◦ 視窗型扭力扳手	<i>Window Torque Wrench</i>	<b>33</b>
◦ 專利超短手工具	<i>Patented Hand Tool Set</i>	<b>35</b>

## INSTRUCTION

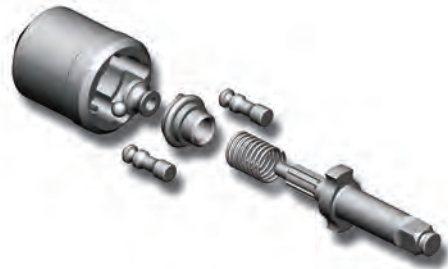

### Pin Clutch Hammer Mechanism

- Extremely stable and smooth torque during operation
- Lower noise, less vibration
- Exceptional durability, easy to service
- For automotive service work and better for assembly lines
- One cycle, spring with drive cam & base and two hammer pins

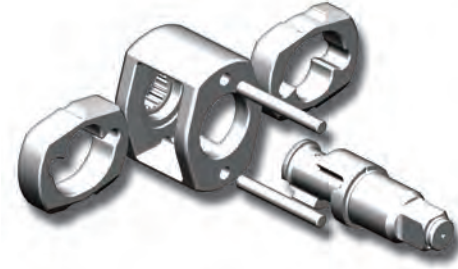

### Twin Hammer Mechanism

- High torque when starting with good continuity
- Endurable impact with consistent torque for long time work
- Quick loosening and tightening for superior performance
- Constructed with precision components and impact mechanism
- One cycle, two hammers

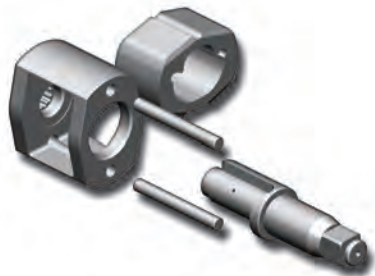

### Jumbo Hammer Mechanism

- Balanced, stable, and smooth torque during operation
- Exceptional durability and long life, easy to service
- Suitable for light duty automotive service work
- No accidental starting without hurts to the bolts.
- One cycle, one hammer.



### Pinless Hammer Mechanism

- One body structure impact mechanism by way of hammer bar and hammer dog
- Endurable and heavy-duty impact mechanism
- An instant blow of strong torque
- Ideal for heavy work
- One cycle, one hammer.

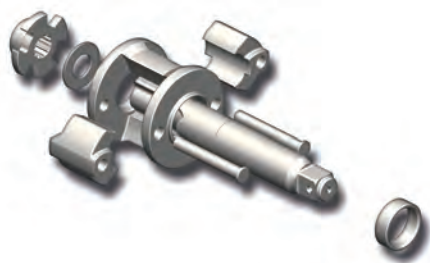

### Two Hammer Mechanism

- Instantaneous high torque with stability.
- Constructed with precision components and impact mechanism.
- Quick loosening and tightening for superior performance.
- Ideal for automotive service work and assembly lines.
- One cycle, two hammers.



### Rocking Dog Hammer Mechanism

- Medium torque without torque of accidental starting
- Suitable for removing and tightening applications of automotive service work
- Simpler impact mechanism, easy to service
- Better for DIY users and non-professional assemblers
- One cycle, one hammer.

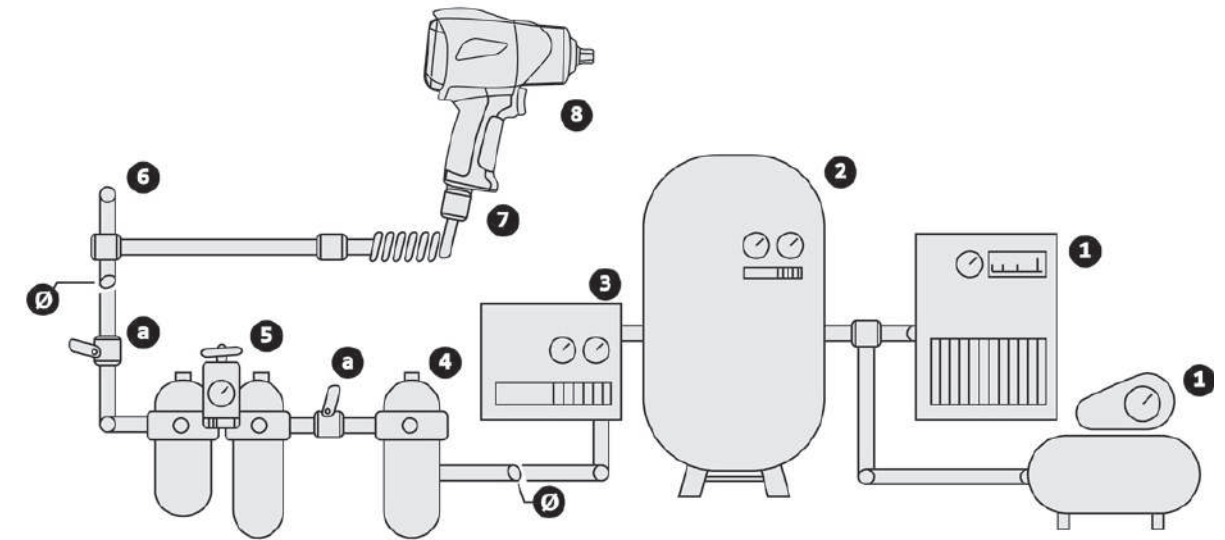

### Air line chart & Air Diagram

- |                   |                                  |
|-------------------|----------------------------------|
| 1. AIR COMPRESSOR | 5. FILTER REGULATOR / LUBRICATOR |
| 2. AIR TANK       | a. SHUT-OFF COCK                 |
| 3. AIR DRYER      | 6. DAILY WATER DRAIN             |
| 4. OIL FILTER     | 7. PRESSURE CHECK POINT          |
| a. SHUT-OFF COCK  | 8. AIR TOOLS                     |

### Tool maintenance & safety instruction

- Always keep the air pressure at 90psi (6.3kg/cm<sup>2</sup>)
- Use proper sockets, couplers, nipples, air hose (don't over 8 feet), pipes and fitting.
- Check the condition of air line accessories, and drain out the water from the separators and air line to keep the air supply system cleaning and dry.
- Check the quick change couplers is in secure connection and in good order.
- Keep the tools properly lubricated to prevent wear and rust.
- Be sure to fill in SAE#10 Lubricating oil into the air inlet before and after using air tools.
- Always use gloves, safety goggles or face shield and ear protector when operating air tools.
- Never wear loose clothing that might get caught in the tool and cause injuries.
- When installing whip hoses or quick coupler directly into the tool, use a liquid pipe sealant to prevent damage to the housing.
- When tools are not in using, clean and lubricate them, then store in a clean and dry place

## AW050H 14mm 超短嵌入式小鋼炮 14mm Super Stubby Air Impact Wrench

**Jumbo Hammer**



**Anvil Changeable: 3/8" Dr. & 1/2" Dr.**  
傳動軸轉接頭: 3/8"Dr. & 1/2"Dr.

**Super Short Special Impact Socket Design**  
超短特殊套筒 13, 17, 19, 21mm

**Magnetic Design: Super Short Bit Attachable**  
內附磁鐵可直接吸附bit使用

**Extension Bar Attached to Increase Length Easily**  
延長桿增加兩倍用途

**8 & 10 Bit Holder Attachable**  
8 & 10mm套筒內附磁鐵可裝bit

Side Exhaust

傳動尺寸 Square Drive	: 1/2"
螺栓規格 Bolt Capacity	: 5/8" (M16)
耗氣量 Avg/ Air Con.	: 4.0 CFM (113 L/min)
進氣接頭 Air Inlet	: 1/4"
進氣壓力 Air Pressure	: 90 PSI (6.2 Bar)
風管內徑 Hose Size I.D.	: 3/8"
工作扭力 Working Torque	: 400 FT-LB / 542 N.m. (5 Sec.)
最大扭力 Max. Torque	: 600 FT-LB / 813 N.m.
空轉轉速 Free Speed	: 9000 RPM
震動值 Vibration	: 11.6 m/s <sup>2</sup>
噪音值 Sound Pressure	: 96.5 Db
工具長度 Overall Length	: 86 mm (3.38")
工具重量 Net Weight	: 1.35 Kg (2.98 LB)
包裝 Packing	: 6 Sets/15.55Kg/16.60kg/1.3'

Patent



- 單錘結構
- 耐磨耗傳動軸
- 握把下排氣
- 單手操控正反轉與變速(各三速)。專利嵌入式裝置
- 專利創新型內凹六邊形傳動軸, 以求多功能運用:
  - 可裝上特殊短套筒 (17, 19, 21mm)以利達到最短距離
  - 可裝上1/2" 或 3/8" 傳動軸, 配合傳統套筒作使用
  - 8 & 10mm套筒內附磁鐵可吸附bit
  - 內附磁鐵。可裝上14mm bit, torx,使用範圍廣泛同時達到短距離效果
- 機構縮短至3.38",小巧輕量符合人體工學,可降低施工空間的限制
- 高扭力, 低噪音(可加裝消音器)
- Mechanism: Jumbo Hammer
- Highest durable Japanese steel anvil
- Handle exhaust
- One hand operation for Forward & Reverse : 3 positions for each side
- Replaceable anvil design for multiple functions :
  - Impact socket (17, 19, 21mm) & Extension bar: 14mm
  - Adapter anvil of 3/8" Dr. & 1/2" Dr.
  - Bit holder : 8 & 10mm
  - H14 & T60 (magnetic design)
- Short Length: only 3.38" allows to easily access in cramped spaces
- Powerful torque with low noise (muffler option)

## ADR001T 可變速氣動點焊鑽 Multiple Speed Air Spot Welding Drill



Low - high Speed SHIFT Device  
速度切換開關



進氣控制, 三階段變速  
Input Air Control  
1-2-3 stage, change speed

Side Exhaust

Patent



點鑽直徑 Spot Drill Dia.	: 8 mm(O.D)
運作馬力 Horsepower	: 0.6 hp
空轉轉速 Free Speed / 3 Stage	: 450/1200 RPM
(Low-high Speed)	: 700/1800 RPM
(± 5% tolerance)	: 900/2400 RPM
進氣壓力 Air Pressures	: 90 psi (6.3 Bar)
進氣接頭 Air Inlet	: 1/4"
工具長度 Overall Length	: 200 mm(7-7/8")
工具重量 Net Weight	: 1.8 kg(3.96 lbs)
包裝 Packing	: 6 Sets/19.44Kg/20.49kg/2.1'

- 6 speed choice (Different from old single speed tool)
- Suitable for HSS & TCT drill
- Work with Steel & Aluminum alloy plate
- 6種速度選擇 (與傳統型單速工具不同)
- 適用於HSS和TCT鑽頭
- 適用於鋼和鋁合金板

AW050H New Air Impact Wrench  
AW050H Air Impact Wrench  
AW050H Air Screwdriver  
AW050H Air Ratchet Wrench  
AW050H Air Die Grinder  
AW050H Air Angle Grinder Series  
AW050H Air Sander  
AW050H Air Spray Gun  
AW050H Air Blow Gun  
AW050H Air Reverter Rivet Nut Tool  
AW050H Window Torque Wrench Series  
AW050H Patented Hand Tool Set

## AW030C 3/8" 迷你輕量型氣動扳手 Stubby Air Impact Wrench

Jumbo Hammer



傳動尺寸 Square Drive	: 3/8"
螺栓規格 Bolt Capacity	: 3/8" (M14)
耗氣量 Avg/ Air Con.	: 3.7 CFM (104 L/min)
進氣接頭 Air Inlet	: 1/4"
進氣壓力 Air Pressure	: 90 PSI (6.2 Bar)
風管內徑 Hose Size I.D.	: 3/8"
工作扭力 Working Torque	: 290 FT-LB / 394 N.m.
最大扭力 Max. Torque	: 320 FT-LB / 435 N.m.
空轉轉速 Free Speed	: 9000 RPM
震動值 Vibration	: 9.0 m/s <sup>2</sup>
噪音值 Sound Pressure	: -
工具長度 Overall Length	: 3-7/8" (96 mm)
工具重量 Net Weight	: 1.32 Kg (2.91 LB)
包裝 Packing	: 10 Pcs/15.3 Kg/15.88 Kg/1.02'

## AW050G 1/2" 迷你輕量型氣動扳手 Stubby Air Impact Wrench

Jumbo Hammer



New!



傳動尺寸 Square Drive	: 1/2"
螺栓規格 Bolt Capacity	: 5/8" (M16)
耗氣量 Avg/ Air Con.	: 4.0 CFM (113 L/min)
進氣接頭 Air Inlet	: 1/4"
進氣壓力 Air Pressure	: 90 PSI (6.2 Bar)
風管內徑 Hose Size I.D.	: 3/8"
工作扭力 Working Torque	: 450 FT-LB / 610 N.m.
最大扭力 Max. Torque	: 600 FT-LB / 813 N.m.
空轉轉速 Free Speed	: 9000 RPM
震動值 Vibration	: 11.6 m/s <sup>2</sup>
噪音值 Sound Pressure	: 97.4 Db
工具長度 Overall Length	: 3-7/8" (99 mm)
工具重量 Net Weight	: 1.33 Kg (2.98 LB)
包裝 Packing	: 10 Pcs/15.3 Kg/15.88 Kg/1.02'

## AW085C 1/2" 輕量複合材鋁合金氣動扳手 Composite Air Impact Wrench

Twin Hammer



傳動尺寸 Square Drive	: 1/2"
螺栓規格 Bolt Capacity	: 7/8" (M24)
耗氣量 Avg/ Air Con.	: 5.5 CFM (158 L/min)
進氣接頭 Air Inlet	: 1/4"
進氣壓力 Air Pressure	: 90 PSI (6.2 Bar)
風管內徑 Hose Size I.D.	: 3/8"
工作扭力 Working Torque	: 650 FT-LB / 881 N.m.
最大扭力 Max. Torque	: 840 FT-LB / 1139 N.m.
空轉轉速 Free Speed	: 8500 RPM
震動值 Vibration	: 8.1 m/s <sup>2</sup>
噪音值 Sound Pressure	: 91.5 Db
工具長度 Overall Length	: 7.48" (190 mm)
工具重量 Net Weight	: 2.2 Kg (4.8 LB)
包裝 Packing	: 10 Pcs/24.0 Kg/25.0 Kg/1.71'

## AW095A 1/2" 輕量複合材鎂合金氣動扳手 Composite Air Impact Wrench

Twin Hammer



New!



傳動尺寸 Square Drive	: 1/2"
螺栓規格 Bolt Capacity	: 1" (M25)
耗氣量 Avg/ Air Con.	: 5.5 CFM (158 L/min)
進氣接頭 Air Inlet	: 1/4"
進氣壓力 Air Pressure	: 90 PSI (6.2 Bar)
風管內徑 Hose Size I.D.	: 3/8"
工作扭力 Working Torque	: 800 FT-LB / 1080 N.m.
最大扭力 Max. Torque	: 950 FT-LB / 1283 N.m.
脫離扭力 Breakaway Torque	: 1200 FT-LB / 1627 N.m.
空轉轉速 Free Speed	: 8500 RPM
震動值 Vibration	: 8.1 m/s <sup>2</sup>
噪音值 Sound Pressure	: 91.5 Db
工具長度 Overall Length	: 6-7/8" (179 mm)
工具重量 Net Weight	: 1.7 Kg (3.75 LB)
包裝 Packing	: 10 Pcs/19.0 Kg/20.0 Kg/1.71'

## AW085D 3/4" 迷你輕量複合材鋁合金氣動扳手 Mini Composite Air Impact Wrench

Twin Hammer



傳動尺寸 Square Drive	: 3/4"
螺栓規格 Bolt Capacity	: 7/8" (M24)
耗氣量 Avg/ Air Con.	: 5.5 CFM (158 L/min)
進氣接頭 Air Inlet	: 1/4"
進氣壓力 Air Pressure	: 90 PSI (6.2 Bar)
風管內徑 Hose Size I.D.	: 3/8"
工作扭力 Working Torque	: 650 FT-LB / 881 N.m.
最大扭力 Max. Torque	: 820 FT-LB / 1111 N.m.
空轉轉速 Free Speed	: 8500 RPM
震動值 Vibration	: 8.1 m/s <sup>2</sup>
噪音值 Sound Pressure	: 91.5 Db
工具長度 Overall Length	: 7-7/8" (200 mm)
工具重量 Net Weight	: 2.3 Kg (5.0 LB)
包裝 Packing	: 10 Pcs/24.5 Kg/25.5 Kg/1.71'

## AW150A 3/4" 輕量複合材鎂合金氣動扳手 Lightweight Composite Air Impact Wrench

Twin Hammer



New!



傳動尺寸 Square Drive	: 3/4"
螺栓規格 Bolt Capacity	: 1-1/4" (M32)
耗氣量 Avg/ Air Con.	: 7.0 CFM (198 L/min)
進氣接頭 Air Inlet	: 3/8"
進氣壓力 Air Pressure	: 90 PSI (6.2 Bar)
風管內徑 Hose Size I.D.	: 3/8"
工作扭力 Working Torque	: 1200 FT-LB / 1687 N.m.
最大扭力 Max. Torque	: 1500 FT-LB / 2108 N.m.
空轉轉速 Free Speed	: 6000 RPM
震動值 Vibration	: 8.6 m/s <sup>2</sup>
噪音值 Sound Pressure	: 96.5 Db
工具長度 Overall Length	: 8-1/4" (209 mm)
工具重量 Net Weight	: 3.0 Kg (6.4 LB)
包裝 Packing	: 6 Pcs/20.0 Kg/21.0 Kg/1.3'

## AW150B

### 1" 迷你輕量複合材鋁合金氣動扳手 Mini Composite Air Impact Wrench

Twin Hammer



Handle Exhaust



傳動尺寸 Square Drive	: 1"
螺栓規格 Bolt Capacity	: 1-1/4" (M32)
耗氣量 Avg/ Air Con.	: 7.0 CFM (198 L/min)
進氣接頭 Air Inlet	: 3/8"
進氣壓力 Air Pressure	: 90 PSI (6.2 Bar)
風管內徑 Hose Size I.D.	: 3/8"
工作扭力 Working Torque	: 1200 FT-LB / 1627 N.m.
最大扭力 Max. Torque	: 1500 FT-LB / 2033 N.m.
空轉轉速 Free Speed	: 5500 RPM
震動值 Vibration	: 8.6 m/s <sup>2</sup>
噪音值 Sound Pressure	: 96.5 Db
工具長度 Overall Length	: 9.10" (230 mm)
工具重量 Net Weight	: 3.8 Kg (8.3 LB)
包裝 Packing	: 6 Pcs/23.9 Kg/24.9 Kg/1.3'

## AW200D / AW200E / AW200F

### 1" 輕量氣動扳手 Lightweight Air Impact Wrench

	AW200D Twin Hammer	AW200E Pinless	AW200F Pin Clutch
傳動尺寸 Square Drive	1"	1"	1"
螺栓規格 Bolt Capacity	1-3/8" (M33)	1-3/8" (M33)	1-3/8" (M33)
耗氣量 Avg/ Air Con.	6.94 CFM (196 L/min)	6.94 CFM (196 L/min)	6.94 CFM (196 L/min)
進氣接頭 Air Inlet	1/2"	1/2"	1/2"
進氣壓力 Air Pressure	90 PSI (6.2 Bar)	90 PSI (6.2 Bar)	90 PSI (6.2 Bar)
風管內徑 Hose Size I.D.	1/2"	1/2"	1/2"
工作扭力 Working Torque	2200 FT-LB / 2983 N.m.	2200 FT-LB / 2983 N.m.	2000 FT-LB / 2712 N.m.
最大扭力 Max. Torque	2700 FT-LB / 3661 N.m.	2600 FT-LB / 3525 N.m.	2500 FT-LB / 3390 N.m.
空轉轉速 Free Speed	5500 RPM	5500 RPM	5500 RPM
震動值 Vibration	9.49 m/s <sup>2</sup>	9.49 m/s <sup>2</sup>	9.49 m/s <sup>2</sup>
噪音值 Sound Pressure	100.1 Db	100.1 Db	100.1 Db
工具長度 Overall Length	2" Anvil: 13.50" (343mm) 6" Anvil: 19.30" (490mm)	2" Anvil: 14.40" (366mm) 6" Anvil: 18.90" (480mm)	2" Anvil: 14.30" (363mm) 6" Anvil: 19.17" (478mm)
工具重量 Net Weight	2" Anvil: 6.65 Kg (14.66 LB) 6" Anvil: 7.72 Kg (17.02 LB)	2" Anvil: 7.64 Kg (16.84 LB) 6" Anvil: 8.58 Kg (18.92 LB)	2" Anvil: 7.5 Kg (16.53 LB) 6" Anvil: 8.35 Kg (18.41 LB)

Top Exhaust



New!



Bottom Exhaust



## AW300A

### 1-1/2" 氣動扳手 Professional Air Impact Wrench

Twin Hammer



Top Exhaust



傳動尺寸 Square Drive	: 1-1/2"
螺栓規格 Bolt Capacity	: 1-3/4" (M44)
耗氣量 Avg/ Air Con.	: 7.0 CFM (198 L/min)
進氣接頭 Air Inlet	: 1/2"
進氣壓力 Air Pressure	: 90 PSI (6.2 Bar)
風管內徑 Hose Size I.D.	: 1/2"
工作扭力 Working Torque	: 2500 FT-LB / 3390 N.m.
最大扭力 Max. Torque	: 3000 FT-LB / 4068 N.m.
空轉轉速 Free Speed	: 3700 RPM
震動值 Vibration	: 5.9 m/s <sup>2</sup>
噪音值 Sound Pressure	: 96 Db
工具長度 Overall Length	: 19-1/4" (490 mm)
工具重量 Net Weight	: 15.2 Kg (33.5 LB)
包裝 Packing	: 1 Pc/17.2 Kg/17.9 Kg/1.32'

## AW250A

### 1" 氣動扳手 Professional Air Impact Wrench

Twin Hammer



Front Exhaust



傳動尺寸 Square Drive	: 1"
螺栓規格 Bolt Capacity	: 1-1/2" (M38)
耗氣量 Avg/ Air Con.	: 7.4 CFM (195 L/min)
進氣接頭 Air Inlet	: 1/2"
進氣壓力 Air Pressure	: 90 PSI (6.2 Bar)
風管內徑 Hose Size I.D.	: 1/2"
工作扭力 Working Torque	: 2200 FT-LB / 2983 N.m.
最大扭力 Max. Torque	: 2500 FT-LB / 3390 N.m.
空轉轉速 Free Speed	: 3800 RPM
震動值 Vibration	: 6.0 m/s <sup>2</sup>
噪音值 Sound Pressure	: 96 Db
工具長度 Overall Length	: 19-1/4" (490 mm)
工具重量 Net Weight	: 14.0 Kg (30.8 LB)
包裝 Packing	: 1 Pc/16.0 Kg/16.6 Kg/1.32'

## AW250B

### 1" 氣動扳手 Professional Pinless Air Impact Wrench

Pin Less



Front Exhaust



傳動尺寸 Square Drive	: 1"
螺栓規格 Bolt Capacity	: 1-1/2" (M38)
耗氣量 Avg/ Air Con.	: 6.0 CFM (170 L/min)
進氣接頭 Air Inlet	: 1/2"
進氣壓力 Air Pressure	: 90 PSI (6.2 Bar)
風管內徑 Hose Size I.D.	: 1/2"
工作扭力 Working Torque	: 2200 FT-LB / 2983 N.m.
最大扭力 Max. Torque	: 2500 FT-LB / 3390 N.m.
空轉轉速 Free Speed	: 3800 RPM
震動值 Vibration	: 6.1 m/s <sup>2</sup>
噪音值 Sound Pressure	: 98 Db
工具長度 Overall Length	: 23-1/4" (590 mm)
工具重量 Net Weight	: 16.0 Kg (35.4 LB)
包裝 Packing	: 1 Pc/18.1 Kg/18.8 Kg/1.32'

## AW200A 1" 氣動扳手 Air Impact Wrench

Twin Hammer



傳動尺寸 Square Drive	: 1"
螺栓規格 Bolt Capacity	: 1-3/8" (M35)
耗氣量 Avg/ Air Con.	: 6.9 CFM (197 L/min)
進氣接頭 Air Inlet	: 1/2"
進氣壓力 Air Pressure	: 90 - 115 PSI (6.2-7.9 Bar)
風管內徑 Hose Size I.D.	: 1/2"
工作扭力 Working Torque	: 1700 FT-LB / 2305 N.m.
最大扭力 Max. Torque	: 2000 FT-LB / 2712 N.m.
空轉轉速 Free Speed	: 4100 RPM
震動值 Vibration	: 6.0 m/s <sup>2</sup>
噪音值 Sound Pressure	: 91 Dba
工具長度 Overall Length	: 13.78" (350 mm)
工具重量 Net Weight	: 8.88 Kg (22.0 LB)
包裝 Packing	: 2 Pcs/19.7 Kg/20.5 Kg/1.5'

## AW200C 1" 氣動扳手 Air Impact Wrench

Pin Clutch



傳動尺寸 Square Drive	: 1"
螺栓規格 Bolt Capacity	: 1-3/8" (M35)
耗氣量 Avg/ Air Con.	: 6.0 CFM (170 L/min)
進氣接頭 Air Inlet	: 1/2"
進氣壓力 Air Pressure	: 90 PSI (6.2 Bar)
風管內徑 Hose Size I.D.	: 1/2"
工作扭力 Working Torque	: 1800 FT-LB / 2440 N.m.
最大扭力 Max. Torque	: 2000 FT-LB / 2712 N.m.
空轉轉速 Free Speed	: 3300 RPM
震動值 Vibration	: 5.8 m/s <sup>2</sup>
噪音值 Sound Pressure	: 91 Dba
工具長度 Overall Length	: 13.78" (350 mm)
工具重量 Net Weight	: 10.5 Kg (23.15 LB)
包裝 Packing	: 2 Pcs/25.2 Kg/26.0 Kg/1.5'

## AW180B 1" 氣動扳手 Professional Air Impact Wrench

Twin Hammer



傳動尺寸 Square Drive	: 1"
螺栓規格 Bolt Capacity	: 1-3/8" (M35)
耗氣量 Avg/ Air Con.	: 6.94 CFM (196 L/min)
進氣接頭 Air Inlet	: 1/2"
進氣壓力 Air Pressure	: 90 PSI (6.2 Bar)
風管內徑 Hose Size I.D.	: 1/2"
工作扭力 Working Torque	: 1800 FT-LB / 2440 N.m.
最大扭力 Max. Torque	: 2000 FT-LB / 2712 N.m.
空轉轉速 Free Speed	: 3300 RPM
震動值 Vibration	: 6.0 m/s <sup>2</sup>
噪音值 Sound Pressure	: 96 Dba
工具長度 Overall Length	: 13.78" (350 mm)
工具重量 Net Weight	: 8.3 Kg (18.3 LB)
包裝 Packing	: 2 Pcs/18.5 Kg/19.4 Kg/1.5'

## AW221A 1" 氣動扳手 Air Impact Wrench

Twin Hammer

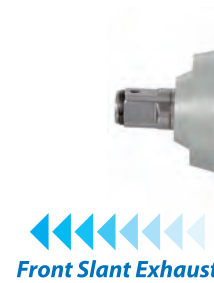

傳動尺寸 Square Drive	: 1"
螺栓規格 Bolt Capacity	: 1-3/8" (M35)
耗氣量 Avg/ Air Con.	: 6.0 CFM (170.0 L/min)
進氣接頭 Air Inlet	: 1/2"
進氣壓力 Air Pressure	: 90 PSI (6.2 Bar)
風管內徑 Hose Size I.D.	: 1/2"
工作扭力 Working Torque	: 1800 FT-LB / 2440 N.m.
最大扭力 Max. Torque	: 2200 FT-LB / 2983 N.m.
空轉轉速 Free Speed	: 5000 RPM
震動值 Vibration	: 7.2 m/s <sup>2</sup>
噪音值 Sound Pressure	: 91.1 Dba
工具長度 Overall Length	: 11-1/2" (290 mm)
工具重量 Net Weight	: 7.9 Kg (17.5 LB)
包裝 Packing	: 2 Pcs/17.3 Kg/17.9 Kg/1.1'

## AW201A 1" 氣動扳手 Air Impact Wrench

Pin Clutch



傳動尺寸 Square Drive	: 1"
螺栓規格 Bolt Capacity	: 1-3/8" (M35)
耗氣量 Avg/ Air Con.	: 6.0 CFM (170.0 L/min)
進氣接頭 Air Inlet	: 1/2"
進氣壓力 Air Pressure	: 90 PSI (6.2 Bar)
風管內徑 Hose Size I.D.	: 1/2"
工作扭力 Working Torque	: 1800 FT-LB / 2440 N.m.
最大扭力 Max. Torque	: 2200 FT-LB / 2983 N.m.
空轉轉速 Free Speed	: 4200 RPM
震動值 Vibration	: 7.2 m/s <sup>2</sup>
噪音值 Sound Pressure	: 91.1 Dba
工具長度 Overall Length	: 11-1/2" (290 mm)
工具重量 Net Weight	: 10.0 Kg (22.0 LB)
包裝 Packing	: 2 Pcs/21.8 Kg/22.4 Kg/1.1'

## NEW PRODUCTS



## AW120A 3/4" 氣動扳手 Air Impact Wrench

Twin Hammer



Handle Exhaust



傳動尺寸	Square Drive	: 3/4"
螺栓規格	Bolt Capacity	: 1-1/4" (M32)
耗氣量	Avg/ Air Con.	: 8.4 CFM (238 L/min)
進氣接頭	Air Inlet	: 3/8"
進氣壓力	Air Pressure	: 90 PSI (6.2 Bar)
風管內徑	Hose Size I.D.	: 1/2"
工作扭力	Working Torque	: 1200 FT-LB / 1627 N.m.
最大扭力	Max. Torque	: 1500 FT-LB / 2034 N.m.
空轉轉速	Free Speed	: 5000 RPM
震動值	Vibration	: 6.4 m/s <sup>2</sup>
噪音值	Sound Pressure	: 89 Db
工具長度	Overall Length	: 8-1/2" (216.5 mm)
工具重量	Net Weight	: 5.1 Kg (11.2 LB)
包裝	Packing	: 4 Pcs/22.3 Kg/23.1 Kg/1.21'

## AW100A 3/4" 氣動扳手 Air Impact Wrench

Twin Hammer



Front Exhaust



傳動尺寸	Square Drive	: 3/4"
螺栓規格	Bolt Capacity	: 1" (M25)
耗氣量	Avg/ Air Con.	: 5.30 CFM (150 L/min)
進氣接頭	Air Inlet	: 1/4"
進氣壓力	Air Pressure	: 90 PSI (6.2 Bar)
風管內徑	Hose Size I.D.	: 3/8"
工作扭力	Working Torque	: 900 FT-LB / 1200 N.m.
最大扭力	Max. Torque	: 1000 FT-LB / 1356 N.m.
空轉轉速	Free Speed	: 6300 RPM
震動值	Vibration	: 5.8 m/s <sup>2</sup>
噪音值	Sound Pressure	: 92 Db
工具長度	Overall Length	: 8-1/4" (210 mm)
工具重量	Net Weight	: 4.3 Kg (9.5 LB)
包裝	Packing	: 4 Pcs/18.7 Kg/19.3 Kg/1.21'

## AW080A 3/4" 氣動扳手 Air Impact Wrench

Pin Clutch



Front Exhaust



傳動尺寸	Square Drive	: 3/4"
螺栓規格	Bolt Capacity	: 7/8" (M24)
耗氣量	Avg/ Air Con.	: 4.2 CFM (119 L/min)
進氣接頭	Air Inlet	: 1/4"
進氣壓力	Air Pressure	: 90 PSI (6.2 Bar)
風管內徑	Hose Size I.D.	: 3/8"
工作扭力	Working Torque	: 700 FT-LB / 949 N.m.
最大扭力	Max. Torque	: 800 FT-LB / 1085 N.m.
空轉轉速	Free Speed	: 4800 RPM
震動值	Vibration	: 5.8 m/s <sup>2</sup>
噪音值	Sound Pressure	: 86 Db
工具長度	Overall Length	: 9-3/4" (248 mm)
工具重量	Net Weight	: 4.6 Kg (10.1 LB)
包裝	Packing	: 4 Pcs/20.1 Kg/20.8 Kg/1.21'

## AW085A 3/4" 氣動扳手 Air Impact Wrench

Pin Clutch



Front Exhaust



傳動尺寸	Square Drive	: 3/4"
螺栓規格	Bolt Capacity	: 7/8" (M24)
耗氣量	Avg/ Air Con.	: 4.2 CFM (119 L/min)
進氣接頭	Air Inlet	: 1/4"
進氣壓力	Air Pressure	: 90 PSI (6.2 Bar)
風管內徑	Hose Size I.D.	: 3/8"
工作扭力	Working Torque	: 700 FT-LB / 949 N.m.
最大扭力	Max. Torque	: 800 FT-LB / 1085 N.m.
空轉轉速	Free Speed	: 4800 RPM
震動值	Vibration	: 5.8 m/s <sup>2</sup>
噪音值	Sound Pressure	: 86 Db
工具長度	Overall Length	: 9-3/4" (248 mm)
工具重量	Net Weight	: 5.0 Kg (11 LB)
包裝	Packing	: 4 Pcs/21.3 Kg/22.1 Kg/1.21'

## AW045A 1/2" 氣動扳手 Air Impact Wrench

Twin Hammer



Front Exhaust



傳動尺寸	Square Drive	: 1/2"
螺栓規格	Bolt Capacity	: 5/8" (M16)
耗氣量	Avg/ Air Con.	: 4.5 CFM (127 L/min)
進氣接頭	Air Inlet	: 1/4"
進氣壓力	Air Pressure	: 90 PSI (6.2 Bar)
風管內徑	Hose Size I.D.	: 3/8"
工作扭力	Working Torque	: 460 FT-LB / 624 N.m.
最大扭力	Max. Torque	: 550 FT-LB / 746 N.m.
空轉轉速	Free Speed	: 7000 RPM
震動值	Vibration	: 4.6 m/s <sup>2</sup>
噪音值	Sound Pressure	: 89 Db
工具長度	Overall Length	: 7-3/8" (188 mm)
工具重量	Net Weight	: 2.5 Kg (5.5 LB)
包裝	Packing	: 10 Pcs/28.2 Kg/29.1 Kg/1.71'

## AW070B 1/2" 工業級氣動扳手 Industrial Air Impact Wrench

Twin Hammer



Handle Exhaust



傳動尺寸	Square Drive	: 1/2"
螺栓規格	Bolt Capacity	: 3/4" (M19)
耗氣量	Avg/ Air Con.	: 4.7 CFM (133 L/min)
進氣接頭	Air Inlet	: 1/4"
進氣壓力	Air Pressure	: 90 PSI (6.2 Bar)
風管內徑	Hose Size I.D.	: 3/8"
工作扭力	Working Torque	: 620 FT-LB / 813 N.m.
最大扭力	Max. Torque	: 720 FT-LB / 976 N.m.
空轉轉速	Free Speed	: 9200 RPM
震動值	Vibration	: 4.3 m/s <sup>2</sup>
噪音值	Sound Pressure	: 86 Db
工具長度	Overall Length	: 6-3/8" (162 mm)
工具重量	Net Weight	: 2.4 Kg (5.29 LB)
包裝	Packing	: 10 Pcs/27.0 Kg/27.9 Kg/1.71'

## AW065A 1/2" 工業級氣動扳手 Industrial Air Impact Wrench

Twin Hammer



Handle Exhaust



傳動尺寸	Square Drive	: 1/2"
螺栓規格	Bolt Capacity	: 3/4" (M19)
耗氣量	Avg/ Air Con.	: 4.7 CFM (133 L/min)
進氣接頭	Air Inlet	: 1/4"
進氣壓力	Air Pressure	: 90 PSI (6.2 Bar)
風管內徑	Hose Size I.D.	: 3/8"
工作扭力	Working Torque	: 550 FT-LB / 745 N.m.
最大扭力	Max. Torque	: 650 FT-LB / 881 N.m.
空轉轉速	Free Speed	: 8400 RPM
震動值	Vibration	: 4.5 m/s <sup>2</sup>
噪音值	Sound Pressure	: 85 Db
工具長度	Overall Length	: 8" (204 mm)
工具重量	Net Weight	: 2.6 Kg (5.7 LB)
包裝	Packing	: 10 Pcs/28.8 Kg/29.7 Kg/1.71'



## AW040A 1/2" 氣動扳手 Air Impact Wrench

Pin Clutch



Front Exhaust



傳動尺寸 Square Drive	: 1/2"
螺栓規格 Bolt Capacity	: 9/16" (M14)
耗氣量 Avg/ Air Con.	: 3.5 CFM (92 L/min)
進氣接頭 Air Inlet	: 1/4"
進氣壓力 Air Pressure	: 90 PSI (6.2 Bar)
風管內徑 Hose Size I.D.	: 3/8"
工作扭力 Working Torque	: 280 FT-LB / 380 N.m.
最大扭力 Max. Torque	: 340 FT-LB / 461 N.m.
空轉轉速 Free Speed	: 8200 RPM
震動值 Vibration	: 4.2 m/s <sup>2</sup>
噪音值 Sound Pressure	: 88 Db
工具長度 Overall Length	: 7-3/8" (188 mm)
工具重量 Net Weight	: 2.2 Kg (4.85 LB)
包裝 Packing	: 10 Pcs/25.5 Kg/26.3 Kg/1.71'

## AW050A 1/2" 氣動扳手 Air Impact Wrench

Pin Clutch



Handle Exhaust



傳動尺寸 Square Drive	: 1/2"
螺栓規格 Bolt Capacity	: 3/4" (M19)
耗氣量 Avg/ Air Con.	: 3.72 CFM (105 L/min)
進氣接頭 Air Inlet	: 1/4"
進氣壓力 Air Pressure	: 90 PSI (6.2 Bar)
風管內徑 Hose Size I.D.	: 3/8"
工作扭力 Working Torque	: 400 FT-LB / 542 N.m.
最大扭力 Max. Torque	: 500 FT-LB / 678 N.m.
空轉轉速 Free Speed	: 7000 RPM
震動值 Vibration	: 4.3 m/s <sup>2</sup>
噪音值 Sound Pressure	: 88 Db
工具長度 Overall Length	: 8" (204 mm)
工具重量 Net Weight	: 2.5 Kg (5.51 LB)
包裝 Packing	: 10 Pcs/26.0 Kg/28.87 Kg/1.71'

## AW020A 3/8" 氣動扳手 Air Impact Wrench

Pin Clutch



1/2" ANVIL OPTION



傳動尺寸 Square Drive	: 3/8" / 1/2"
螺栓規格 Bolt Capacity	: 1/2" (M13)
耗氣量 Avg/ Air Con.	: 3.0 CFM (82 L/min)
進氣接頭 Air Inlet	: 1/4"
進氣壓力 Air Pressure	: 90 PSI (6.2 Bar)
風管內徑 Hose Size I.D.	: 3/8"
工作扭力 Working Torque	: 220 FT-LB / 298 N.m.
最大扭力 Max. Torque	: 240 FT-LB / 325 N.m.
空轉轉速 Free Speed	: 9500 RPM
震動值 Vibration	: 4.7 m/s <sup>2</sup>
噪音值 Sound Pressure	: 88 Db
工具長度 Overall Length	: 6-1/2" (165 mm)
工具重量 Net Weight	: 1.4 Kg (3.1 LB)
包裝 Packing	: 10 Pcs/16.0 Kg/16.6 Kg/1.02'

## AW020B 3/8" 氣動扳手 Air Impact Wrench

Jumbo Hammer



1/2" ANVIL OPTION



傳動尺寸 Square Drive	: 3/8" / 1/2"
螺栓規格 Bolt Capacity	: 1/2" (M13)
耗氣量 Avg/ Air Con.	: 3.0 CFM (85.8 L/min)
進氣接頭 Air Inlet	: 1/4"
進氣壓力 Air Pressure	: 90 PSI (6.2 Bar)
風管內徑 Hose Size I.D.	: 3/8"
工作扭力 Working Torque	: 200 FT-LB / 271 N.m.
最大扭力 Max. Torque	: 220 FT-LB / 298 N.m.
空轉轉速 Free Speed	: 9500 RPM
震動值 Vibration	: 4.8 m/s <sup>2</sup>
噪音值 Sound Pressure	: 88 Db
工具長度 Overall Length	: 6-1/2" (165 mm)
工具重量 Net Weight	: 1.4 Kg (3.1 LB)
包裝 Packing	: 10 Pcs/15.8 Kg/16.4 Kg/1.02'

## AW020C 3/8" 氣動扳手 Air Impact Wrench

Pin Clutch



Front Exhaust

1/2" ANVIL OPTION



傳動尺寸 Square Drive	: 3/8" / 1/2"
螺栓規格 Bolt Capacity	: 1/2" (M13)
耗氣量 Avg/ Air Con.	: 3.0 CFM (85.8 L/min)
進氣接頭 Air Inlet	: 1/4"
進氣壓力 Air Pressure	: 90 PSI (6.2 Bar)
風管內徑 Hose Size I.D.	: 3/8"
工作扭力 Working Torque	: 190 FT-LB / 258 N.m.
最大扭力 Max. Torque	: 220 FT-LB / 298 N.m.
空轉轉速 Free Speed	: 10200 RPM
震動值 Vibration	: 4.5 m/s <sup>2</sup>
噪音值 Sound Pressure	: 88 Db
工具長度 Overall Length	: 5-7/8" (150 mm)
工具重量 Net Weight	: 1.3 Kg (3.0 LB)
包裝 Packing	: 10 Pcs/15.7 Kg/16.28 Kg/1.02'

## AW030A 3/8" 氣動扳手 Air Impact Wrench

Twin Hammer



Handle Exhaust



傳動尺寸 Square Drive	: 3/8"
螺栓規格 Bolt Capacity	: 9/16" (M14)
耗氣量 Avg/ Air Con.	: 3.0 CFM (85.8 L/min)
進氣接頭 Air Inlet	: 1/4"
進氣壓力 Air Pressure	: 90 PSI (6.2 Bar)
風管內徑 Hose Size I.D.	: 3/8"
工作扭力 Working Torque	: 250 FT-LB / 339 N.m.
最大扭力 Max. Torque	: 290 FT-LB / 393 N.m.
空轉轉速 Free Speed	: 10500 RPM
震動值 Vibration	: 4.9 m/s <sup>2</sup>
噪音值 Sound Pressure	: 88 Db
工具長度 Overall Length	: 6-1/2" (165 mm)
工具重量 Net Weight	: 1.3 Kg (2.9 LB)
包裝 Packing	: 10 Pcs/15.7 Kg/16.28 Kg/1.02'

AO080AGP  
AW050H  
New Air  
Impact Wrench  
Air Impact  
Wrench  
Screwdriver  
Air  
Ratchet  
Wrench  
Die Grinder  
Air  
Angle  
Grinder Series  
Air Sander  
Air Spray Gun  
Air Blow Gun  
Air Reverser  
Nut Tool  
Window Torque  
Wrench Series  
Patented  
Hand Tool Set

## AD312A 高扭力氣動起子 High Torque Air Screwdriver

Pin Clutch



螺栓規格 Bolt Capacity	: $\phi$ 3-12
耗氣量 Avg/ Air Con.	: 2.98 CFM (84 L/min)
進氣接頭 Air Inlet	: 1/4"
進氣壓力 Air Pressure	: 90 PSI (6.2 Bar)
風管內徑 Hose Size I.D.	: 1/4"
工作扭力 Max. Torque	: 190 FT-LB / 257 N.m.
空轉轉速 Free Speed	: 9000 RPM
工具長度 Overall Length	: 220 mm
工具重量 Net Weight	: 1.35 Kg (2.97 LB)
包裝 Packing	: 10 Pcs/16.95 Kg/17.5 Kg/1.02'



## AD314A 高扭力氣動起子 High Torque Air Screwdriver

Pin Clutch



螺栓規格 Bolt Capacity	: $\phi$ 3-14
耗氣量 Avg/ Air Con.	: 3.03 CFM (85.7 L/min)
進氣接頭 Air Inlet	: 1/4"
進氣壓力 Air Pressure	: 90 PSI (6.2 Bar)
風管內徑 Hose Size I.D.	: 1/4"
工作扭力 Max. Torque	: 220 FT-LB / 298 N.m.
空轉轉速 Free Speed	: 9500 RPM
工具長度 Overall Length	: 220 mm
工具重量 Net Weight	: 1.40 Kg (3.10 LB)
包裝 Packing	: 10 Pcs/17.45 Kg/18.0 Kg/1.02'



## ASD001P 氣動起子 Air Screwdriver

Jumbo Hammer



螺栓規格 Bit Driver	: 1/4"
耗氣量 Avg/ Air Con.	: 4.0 CFM (113 L/min)
進氣接頭 Air Inlet	: 1/4"
進氣壓力 Air Pressure	: 90 PSI (6.2 Bar)
風管內徑 Hose Size I.D.	: 3/8"
工作扭力 Torque (5 Sec)	: 450 FT-LB / 610 N.m.
Torque (10 Sec)	: 600 FT-LB / 813 N.m.
空轉轉速 Free Speed	: 9000 RPM
工具長度 Overall Length	: 101 mm (3.97")
工具重量 Net Weight	: 1.35 Kg (2.98 LB)
包裝 Packing	: 10 Pcs/15.3 Kg/15.88 Kg/1.02'



Handle Exhaust

## AD510A 強力型氣動起子 High Torque Air Screwdriver

Twin Hammer



螺栓規格 Bolt Capacity	: $\phi$ 8-10
耗氣量 Avg/ Air Con.	: 3.03 CFM (85.7 L/min)
進氣接頭 Air Inlet	: 1/4"
進氣壓力 Air Pressure	: 90 PSI (6.2 Bar)
風管內徑 Hose Size I.D.	: 1/4"
工作扭力 Max. Torque	: 250 N.m.
空轉轉速 Free Speed	: 9000 RPM
工具長度 Overall Length	: 215 mm
工具重量 Net Weight	: 1.15 Kg
包裝 Packing	: 25 Pcs/31.0 Kg/32.0 Kg/1.0'



## AD409B 高速氣動起子 High Speed Air Screwdriver

Two Hammer



螺栓規格 Bolt Capacity	: $\phi$ 4-8
耗氣量 Avg/ Air Con.	: 3.0 CFM (82 L/min)
進氣接頭 Air Inlet	: 1/4"
進氣壓力 Air Pressure	: 90 PSI (6.2 Bar)
風管內徑 Hose Size I.D.	: 1/4"
工作扭力 Max. Torque	: 60 FT-LB / 80 N.m.
空轉轉速 Free Speed	: 8000 RPM
工具長度 Overall Length	: 165 mm
工具重量 Net Weight	: 1.05 Kg (2.43 LB)
包裝 Packing	: 25 Pcs/31.0 Kg/32.0 Kg/1.0'



## AD206B 高扭力氣動起子 High Torque Air Screwdriver

Two Hammer



螺栓規格 Bolt Capacity	: $\phi$ 2-5
耗氣量 Avg/ Air Con.	: 2.3 CFM (63 L/min)
進氣接頭 Air Inlet	: 1/4"
進氣壓力 Air Pressure	: 90 PSI (6.2 Bar)
風管內徑 Hose Size I.D.	: 1/4"
工作扭力 Max. Torque	: 33 FT-LB / 45 N.m.
空轉轉速 Free Speed	: 9000 RPM
工具長度 Overall Length	: 6-1/2" (165 mm)
工具重量 Net Weight	: 0.69 Kg (1.52 LB)
包裝 Packing	: 25 Pcs/22.3 Kg/23.3 Kg/0.8'



## ARW3001

## ARW5001

氣動棘輪扳手  
Air Ratchet Wrench



產品編號 Item Number	: ARW3001	ARW5001
傳動尺寸 Square Drive	: 3/8"	1/2"
耗氣量 Avg/ Air Con.	: 3.90 CFM	3.90 CFM
工作扭力 Torque	: 80 FT-LB	80 FT-LB
空轉轉速 Free Speed	: 180 RPM	180 RPM
噪音值 Sound Pressure	: 98 Db	98 Db
工具長度 Overall Length	: 242.0 mm	242.0 mm
工具重量 Net Weight	: 1.17 Kg	1.17 Kg
包裝 Packing	: 10Pcs/11.7Kg/13.1Kg/0.53'	

## ARW3002

## ARW5002

氣動棘輪扳手  
Air Ratchet Wrench



產品編號 Item Number	: ARW3002	ARW5002
傳動尺寸 Square Drive	: 3/8"	1/2"
耗氣量 Avg/ Air Con.	: 3.90 CFM	3.90 CFM
工作扭力 Torque	: 80 FT-LB	80 FT-LB
空轉轉速 Free Speed	: 180 RPM	180 RPM
噪音值 Sound Pressure	: 98 Db	98 Db
工具長度 Overall Length	: 277.0 mm	277.0 mm
工具重量 Net Weight	: 1.24 Kg	1.25 Kg
包裝 Packing	: 10Pcs/12.5Kg/13.9Kg/0.6'	

## ARW3003

## ARW5003

氣動棘輪扳手  
Air Ratchet Wrench



產品編號 Item Number	: ARW3003	ARW5003
傳動尺寸 Square Drive	: 3/8"	1/2"
耗氣量 Avg/ Air Con.	: 3.90 CFM	3.90 CFM
工作扭力 Torque	: 80 FT-LB	80 FT-LB
空轉轉速 Free Speed	: 180 RPM	180 RPM
噪音值 Sound Pressure	: 98 Db	98 Db
工具長度 Overall Length	: 268.0 mm	268.0 mm
工具重量 Net Weight	: 1.18 Kg	1.18 Kg
包裝 Packing	: 10Pcs/11.9Kg/13.3Kg/0.6'	

## ARW3004

## ARW5004

氣動棘輪扳手  
Heavy Duty  
Air Ratchet Wrench



Side Exhaust

產品編號 Item Number	: ARW3004	ARW5004
傳動尺寸 Square Drive	: 3/8"	1/2"
耗氣量 Avg/ Air Con.	: 4.90 CFM	4.90 CFM
工作扭力 Torque	: 120 FT-LB	120 FT-LB
空轉轉速 Free Speed	: 170 RPM	170 RPM
噪音值 Sound Pressure	: 95 Db	95 Db
工具長度 Overall Length	: 320.0 mm	320.0 mm
工具重量 Net Weight	: 1.55 Kg	1.56 Kg
包裝 Packing	: 10Pcs/15.6Kg/17.3Kg/0.84'	

## ARW3005

## ARW1001

氣動棘輪扳手  
Heavy Duty  
Air Ratchet Wrench



Side Exhaust

產品編號 Item Number	: ARW3005	ARW1001
傳動尺寸 Square Drive	: 3/8"	1/4"
耗氣量 Avg/ Air Con.	: 3.50 CFM	3.50 CFM
工作扭力 Torque	: 42 FT-LB	42 FT-LB
空轉轉速 Free Speed	: 270 RPM	270 RPM
噪音值 Sound Pressure	: 98 Db	98 Db
工具長度 Overall Length	: 222.0 mm	222.0 mm
工具重量 Net Weight	: 0.68 Kg	0.68Kg
包裝 Packing	: 20Pcs/13.6Kg/15.2Kg/0.69'	

## AR040BTM3

迷你氣動棘輪扳手  
Mini Air Ratchet Wrench  
Impact Type Low Reaction Force



傳動尺寸 Square Drive	: 3/8"
耗氣量 Avg/ Air Con.	: 2.40 CFM
工作扭力 Torque	: 40 FT-LB
空轉轉速 Free Speed	: 550 RPM
噪音值 Sound Pressure	: 86 Db
工具長度 Overall Length	: 160.0 mm
工具重量 Net Weight	: 0.65 Kg
包裝 Packing	: 20Pcs/13Kg/14.6Kg/0.48'

## ARW3006

## ARW1002

迷你氣動棘輪扳手  
Mini Air Ratchet Wrench



產品編號 Item Number	: ARW3006	ARW1002
傳動尺寸 Square Drive	: 3/8"	1/4"
耗氣量 Avg/ Air Con.	: 3.00 CFM	3.00 CFM
工作扭力 Torque	: 40 FT-LB	40 FT-LB
空轉轉速 Free Speed	: 320 RPM	320 RPM
噪音值 Sound Pressure	: 89 Db	89 Db
工具長度 Overall Length	: 176.0 mm	176.0 mm
工具重量 Net Weight	: 0.55 Kg	0.55 Kg
包裝 Packing	: 20Pcs/11Kg/12.6Kg/0.6'	

## ARW3007

迷你氣動棘輪扳手  
Mini Air Ratchet Wrench  
Wobble Type



傳動尺寸 Square Drive	: 3/8"
耗氣量 Avg/ Air Con.	: 3.00 CFM
工作扭力 Torque	: 40 FT-LB
空轉轉速 Free Speed	: 320 RPM
噪音值 Sound Pressure	: 89 Db
工具長度 Overall Length	: 176.0 mm
工具重量 Net Weight	: 0.55 Kg
包裝 Packing	: 20Pcs/11Kg/12.6Kg/0.6'

## AR025BGM2

## AR025BGM3

超微型迷你氣動棘輪扳手  
Super Duty  
Mini Air Ratchet Wrench



132mm

產品編號 Item Number	: AR025BGM2	AR025BGM3
傳動尺寸 Square Drive	: 1/4"	3/8"
耗氣量 Avg/ Air Con.	: 2.30 CFM	2.30 CFM
工作扭力 Torque	: 25 FT-LB	25 FT-LB
空轉轉速 Free Speed	: 320 RPM	320 RPM
噪音值 Sound Pressure	: 91 Db	91 Db
工具長度 Overall Length	: 132.0 mm	132.0 mm
工具重量 Net Weight	: 0.46 Kg	0.47 Kg
包裝 Packing	: 20Pcs/9.4Kg/11Kg/0.38'	

## ARW3008

## ARW1003

超微型迷你氣動棘輪扳手  
Super Duty  
Mini Air Ratchet Wrench



136mm

產品編號 Item Number	: ARW3008	ARW1003
傳動尺寸 Square Drive	: 3/8"	1/4"
耗氣量 Avg/ Air Con.	: 2.30 CFM	2.30 CFM
工作扭力 Torque	: 20 FT-LB	20 FT-LB
空轉轉速 Free Speed	: 300 RPM	300 RPM
噪音值 Sound Pressure	: 94 Db	94 Db
工具長度 Overall Length	: 136.0 mm	136.0 mm
工具重量 Net Weight	: 0.49 Kg	0.48 Kg
包裝 Packing	: 20Pcs/9.8Kg/11.4Kg/0.38'	

AO080ACP  
AW050H  
New Air  
Impact Wrench  
Air Impact  
Wrench  
Air  
Screwdriver  
Air Ratchet  
Wrench  
Air  
Die Grinder  
Air Angle  
Grinder Series  
Air Sander  
Air Spray Gun  
Air Blow Gun  
Air Reverser  
Nut Tool  
Window Torque  
Wrench Series  
Patented  
Hand Tool Set

## AG260C2M

### 迷你氣動刻模機 Mini Air Die Grinder



夾頭尺寸 Collet	: 1/4"
耗氣量 Avg/ Air Con.	: 3.0 CFM (22 SCFM)
進氣接頭 Air Inlet	: 1/4"
進氣壓力 Air Pressure	: 90 PSI (6.2 BAR)
風管內徑 Hose Size I.D.	: 5/16"
馬力 Horse Power	: 0.5 HP
空轉轉速 Free Speed	: 26,000 RPM
噪音值 Sound Pressure	: 86 Db
工具長度 Overall Length	: 5.28" (134 mm)
工具重量 Net Weight	: 0.79 lbs (0.36 Kgs)
包裝 Packing	: 20 Pcs/11.5 Kg/12.5 Kg/0.72'

## AG200C2A

### 氣動角度刻模機 Air Angle Die Grinder



夾頭尺寸 Collet	: 1/4"
耗氣量 Avg/ Air Con.	: 3.0 CFM (22 SCFM)
進氣接頭 Air Inlet	: 1/4"
進氣壓力 Air Pressure	: 90 PSI (6.2 BAR)
風管內徑 Hose Size I.D.	: 5/16"
馬力 Horse Power	: 0.5 HP
空轉轉速 Free Speed	: 20,000 RPM
噪音值 Sound Pressure	: 93 Db
工具長度 Overall Length	: 5.51" (140 mm)
工具重量 Net Weight	: 1.10 lbs (0.50 Kgs)
包裝 Packing	: 20 Pcs/12.0 Kg/13.0 Kg/0.72'

## AG200C2S

### 氣動刻模機 Air Die Grinder



夾頭尺寸 Collet	: 1/4" / 6 mm
耗氣量 Avg/ Air Con.	: 4.5 CFM (32 SCFM)
進氣接頭 Air Inlet	: 1/4"
進氣壓力 Air Pressure	: 90 PSI (6.2 BAR)
風管內徑 Hose Size I.D.	: 3/8"
馬力 Horse Power	: 1.0 HP
空轉轉速 Free Speed	: 20,000 RPM
震動值 Vibration	: 1.2 M/s <sup>2</sup>
噪音值 Sound Pressure	: 85 Db / 95 Db
工具長度 Overall Length	: 8.07" (208 mm)
工具重量 Net Weight	: 2.16 lbs (0.98 Kgs)
包裝 Packing	: 10 Pcs/10.0 Kg/11.0 Kg/0.52'

## AG120C2A

### 氣動角度刻模機 Air Angle Die Grinder



夾頭尺寸 Collet	: 1/4" / 6 mm
耗氣量 Avg/ Air Con.	: 4.5 CFM (32 SCFM)
進氣接頭 Air Inlet	: 1/4"
進氣壓力 Air Pressure	: 90 PSI (6.2 BAR)
風管內徑 Hose Size I.D.	: 3/8"
馬力 Horse Power	: 1.0 HP
空轉轉速 Free Speed	: 12,000 RPM
震動值 Vibration	: 1.7 M/s <sup>2</sup>
噪音值 Sound Pressure	: 89 Db / 95 Db
工具長度 Overall Length	: 9.13" (232 mm)
工具重量 Net Weight	: 2.29 lbs (1.04 Kgs)
包裝 Packing	: 10 Pcs/13.4Kg/14.4Kg/0.82'

## AG230C2E

### 氣動角度刻模機 Extended Air Angle Die Grinder



夾頭尺寸 Collet	: 1/4" / 6 mm
耗氣量 Avg/ Air Con.	: 3.0 CFM (22 SCFM)
進氣接頭 Air Inlet	: 1/4"
進氣壓力 Air Pressure	: 90 PSI (6.2 BAR)
風管內徑 Hose Size I.D.	: 5/16"
馬力 Horse Power	: 0.5 HP
空轉轉速 Free Speed	: 23,000 RPM
震動值 Vibration	: -
噪音值 Sound Pressure	: -
工具長度 Overall Length	: 268 mm
工具重量 Net Weight	: 0.68 Kgs
包裝 Packing	: 20 Pcs/13.2 Kg/14.2 Kg/1.37'

## AM100B3T

### 精密渦輪刻模機 Precision Turbine Grinder



夾頭尺寸 Collet	: 1/8" / 3mm
耗氣量 Avg/ Air Con.	: 1.0 CFM (7.0 SCFM)
進氣接頭 Air Inlet	: 1/4"
進氣壓力 Air Pressure	: 90 PSI (6.2 BAR)
風管內徑 Hose Size I.D.	: 3/16"
馬力 Horse Power	: 0.06 HP
空轉轉速 Free Speed	: 100,000 RPM
噪音值 Sound Pressure	: 86 Db
工具長度 Overall Length	: 7.48" (190 mm)
附帶軟管 with Black Hose	: 4'9" (1,450 mm)
工具重量 Net Weight	: 0.66 lbs (0.30 Kgs)
包裝 Packing	: 10 Pcs/10.5Kg/11.5Kg/1.37'

## AM540B3S

### 氣動筆型刻模機 Air Pencil Die Grinder W/Grip



夾頭尺寸 Collet	: 1/8" / 3 mm
耗氣量 Avg/ Air Con.	: 0.85 CFM
進氣接頭 Air Inlet	: 1/4"
進氣壓力 Air Pressure	: 90 PSI (6.2 BAR)
風管內徑 Hose Size I.D.	: 5/16"
馬力 Horse Power	: -
空轉轉速 Free Speed	: 54,000 RPM
噪音值 Sound Pressure	: 72 Db / 84 Db
工具長度 Overall Length	: 5-3/8" (137 mm)
工具重量 Net Weight	: 0.44 lbs (0.2 Kgs)
包裝 Packing	: 20 Pcs/7.2 Kg/8.0 Kg/1.18'

## AM700B3S

### 氣動筆型刻模機 Air Pencil Die Grinder W/Grip



夾頭尺寸 Collet	: 1/8" / 3 mm
耗氣量 Avg/ Air Con.	: 1.0 CFM (7.0 SCFM)
進氣接頭 Air Inlet	: 1/4"
進氣壓力 Air Pressure	: 90 PSI (6.2 BAR)
風管內徑 Hose Size I.D.	: 5/16"
馬力 Horse Power	: 0.1 HP
空轉轉速 Free Speed	: 70,000 RPM
震動值 Vibration	: 2.0 M/s <sup>2</sup>
噪音值 Sound Pressure	: 81 Db / 86 Db
工具長度 Overall Length	: 5-3/8" (137 mm)
工具重量 Net Weight	: 0.44 lbs (0.20 Kgs)
包裝 Packing	: 20 Pcs/7.2 Kg/8.0 Kg/1.20'

## AM700B3A

### 氣動筆型直角刻模機 Right Angle Air Pencil Die Grinder W/Grip



夾頭尺寸 Collet	: 1/8"
耗氣量 Avg/ Air Con.	: 4.5 CFM (32 SCFM)
進氣接頭 Air Inlet	: 1/4"
進氣壓力 Air Pressure	: 90 PSI (6.2 BAR)
風管內徑 Hose Size I.D.	: 5/16"
空轉轉速 Free Speed	: 70,000 RPM
震動值 Vibration	: 1.2 M/s <sup>2</sup>
噪音值 Sound Pressure	: 72 Db / 84 Db
工具長度 Overall Length	: 5.9" (150 mm)
附帶軟管 with Black Hose	: 4.9' (1,500 mm)
工具重量 Net Weight	: 0.5 lbs (0.23 Kgs)
包裝 Packing	: 20 Pcs/7.40 Kg/8.40 Kg/1.13'

AO080ACP  
AW050H  
New Air  
Impact Wrench  
Air Impact  
Wrench  
Screwdriver  
Air  
Ratchet  
Wrench  
Air  
Die Grinder  
Air Angle  
Grinder Series  
Air Sander  
Air Spray Gun  
Air Blow Gun  
Air Reverser  
Nut Tool  
Window Torque  
Wrench Series  
Patented  
Hand Tool Set

## AG220D2M

### 氣動刻模機 Air Die Grinder



夾頭尺寸	Collet	: 1/4" (6mm)
耗氣量	Avg/ Air Con.	: 2.1CFM
進氣接頭	Air Inlet	: 1/4"
風管內徑	Hose Size I.D.	: 5 mm
馬力	Horse Power	: 0.45 HP
空轉轉速	Free Speed	: 22,000 RPM
震動值	Vibration	: 2.5 m/s <sup>2</sup>
噪音值	Sound Pressure	: 73 Db
工具長度	Overall Length	: 150 mm
工具重量	Net Weight	: 0.4 Kgs
包裝	Packing	: 20Pcs/10.5Kg/11.0Kg/0.5'

## AG220D2A

### 氣動角度刻模機 Air Angle Die Grinder



夾頭尺寸	Collet	: 1/4" (6mm)
耗氣量	Avg/ Air Con.	: 2.45CFM
進氣接頭	Air Inlet	: 1/4"
風管內徑	Hose Size I.D.	: 5 mm
馬力	Horse Power	: 0.4 HP
空轉轉速	Free Speed	: 22,000 RPM
震動值	Vibration	: 2.5 m/s <sup>2</sup>
噪音值	Sound Pressure	: 80 Db
工具長度	Overall Length	: 170 mm
工具重量	Net Weight	: 0.55 Kgs
包裝	Packing	: 20Pcs/11.3Kg/12.0Kg/1.1'

## AGD005A

### 97° 氣動角度刻模機 Air Angle Die Grinder



夾頭尺寸	Collet	: 1/4" (6mm)
耗氣量	Avg/ Air Con.	: 2.45CFM
進氣接頭	Air Inlet	: 1/4"
風管內徑	Hose Size I.D.	: 6 mm
馬力	Horse Power	: 0.5 HP
空轉轉速	Free Speed	: 15,000 RPM
震動值	Vibration	: 2.5 m/s <sup>2</sup>
噪音值	Sound Pressure	: 78 Db
工具長度	Overall Length	: 180 mm
工具重量	Net Weight	: 0.75 Kgs
包裝	Packing	: 20Pcs/15.1Kg/16.0Kg/1.6'

## AGD002A

### 50mm 氣動角度砂輪機 Air Angle Wheel Grinder



磨盤輪徑	Wheel Diameter	: 50mm
耗氣量	Avg/ Air Con.	: 2.0CFM
進氣接頭	Air Inlet	: 1/4"
風管內徑	Hose Size I.D.	: 6.5mm
空轉轉速	Free Speed	: 22,000 RPM
震動值	Vibration	: 2.5 m/s <sup>2</sup>
噪音值	Sound Pressure	: 75 Db
工具長度	Overall Length	: 177 mm
工具重量	Net Weight	: 0.51 Kgs
包裝	Packing	: 20Pcs/11.3Kg/12.0Kg/1.1'

## AGD001A

### 5" 氣動砂輪機 Air Angle Wheel Grinder



磨盤輪徑	Wheel Diameter	: 7-3/4"
耗氣量	Avg/ Air Con.	: 6.0 CFM
進氣接頭	Air Inlet	: 1/4"
進氣壓力	Air Pressure	: 90 PSI (6.2 BAR)
風管內徑	Hose Size I.D.	: 3/8"
空轉轉速	Free Speed	: 12,000 RPM
工具長度	Overall Length	: 9" (228.6 mm)
工具重量	Net Weight	: 1.82 Kgs (4.0 Lbs)
包裝	Packing	: 10 Pcs/20 Kg/21 Kg/1.45'

## AG190A2AS

### 2" 氣動砂輪機 Mini Air Angle Wheel Grinder



磨盤輪徑	Wheel Diameter	: 2"
耗氣量	Avg/ Air Con.	: 2.6 CFM
進氣接頭	Air Inlet	: 1/4"
進氣壓力	Air Pressure	: 90 PSI (6.2 BAR)
風管內徑	Hose Size I.D.	: 3/8"
空轉轉速	Free Speed	: 19,000 RPM
工具長度	Overall Length	: 5.70" (145 mm)
工具重量	Net Weight	: 0.55Kg (1.21 Lbs)
包裝	Packing	: 20Pcs/14.2Kg/15.2Kg/1.25'

## AA700A31

### 氣動齒鋸 Gear Air Saw



磨盤輪徑	Wheel Diameter	: 7-3/4"
耗氣量	Avg/ Air Con.	: 4.0 CFM (28 SCFM)
進氣接頭	Air Inlet	: 1/4"
進氣壓力	Air Pressure	: 90 PSI (6.2 BAR)
風管內徑	Hose Size I.D.	: 5/16"
空轉轉速	Free Speed	: 7,000 RPM
噪音值	Sound level (pressure)	: 88.5 Db, Kpa:0.45 Db
	Sound level (power)	: 99.5 Db, Kwa:0.38 Db
工具長度	Overall Length	: 10.51" (267 mm)
工具重量	Stroke Length	: 10 mm
包裝	Net Weight	: 2.07 lbs (0.94 Kgs)
	Packing	: 10 Pcs/11.7Kg/12.2Kg/0.58' (14T / 32 T saw blade)

14T saw blade

AO080AGP  
AW050H  
New Air  
Impact Wrench  
Air Impact  
Wrench  
Screwdriver  
Air Ratchet  
Wrench  
Air  
Die Grinder  
Angle Grinder  
& Air Saw  
Air Sander  
Air Spray Gun  
Air Blow Gun  
Air Reverter  
Rivet Nut Tool  
Window Torque  
Wrench Series  
Patented  
Hand Tool Set

## AS050CSV5

### 掌上型自吸式砂光機 Self-Vacuum Palm Air Orbital Sander

## AS050CSV6

產品編號	Item Number	AS050CSV5	AS050CSV6
底盤尺寸	Pad Size	5" Pad	6" Pad
偏擺軌道	Diameter Orbit	5.0mm	
主軸螺紋	Spindle	5/16"-24 UNF	
耗氣量	Avg/ Air Con.	2.5CFM	
進氣接頭	Air Inlet	1/4"	
進氣壓力	Air Pressure	90 PSI (6.2 BAR)	
風管內徑	Hose Size I.D.	3/8"	
空轉轉速	Free Speed	10,000 RPM	
噪音值	Sound Pressure	83 DbA	
集塵系統	Dust System	Self-Vacuum	
工具重量	Net Weight	0.94 Kgs	
包裝	Packing	6 Pcs/7.45Kg/8.45Kg/1.28'	



## AGD003A

### 氣動角度砂光機(3.0mm) Air Angle Sander

類型	Type	Dual Action
底盤尺寸	Pad Size	2" Pad
偏擺軌道	Diameter Orbit	3.0 mm
耗氣量	Avg/ Air Con.	2.1CFM
進氣接頭	Air Inlet	1/4"
風管內徑	Hose Size I.D.	6 mm
空轉轉速	Free Speed	15,000 RPM
震動值	Vibration	2.5 m/s <sup>2</sup>
噪音值	Sound Pressure	77 DbA
工具重量	Net Weight	0.65 Kgs
工具長度	Length	180 mm
包裝	Packing	20pcs/1.1cu-ft/G.W.:14kgs



## AGD004A

### 氣動角度砂光機 Air Angle Sander

底盤尺寸	Pad Size	2"-4" Pad
耗氣量	Avg/ Air Con.	2.1CFM
進氣接頭	Air Inlet	1/4"
風管內徑	Hose Size I.D.	6 mm
空轉轉速	Free Speed	3,200 RPM
震動值	Vibration	2.5 m/s <sup>2</sup>
噪音值	Sound Pressure	77 DbA
工具重量	Net Weight	0.8 Kgs
工具長度	Length	175 mm
包裝	Packing	20pcs/1.1cu-ft/G.W.:18kgs



## AS050CNV5

### 掌上型不吸式砂光機 Non-Vacuum Palm Air Orbital Sander

## AS050CNV6

產品編號	Item Number	AS050ANV5	AS050ANV6
底盤尺寸	Pad Size	5" Pad	6" Pad
偏擺軌道	Diameter Orbit	5.0mm	
主軸螺紋	Spindle	5/16"-24 UNF	
耗氣量	Avg/ Air Con.	2.5 CFM	
進氣接頭	Air Inlet	1/4"	
進氣壓力	Air Pressure	90 PSI (6.2 BAR)	
空轉轉速	Free Speed	10,000 RPM	
噪音值	Sound Pressure	83 DbA	
集塵系統	Dust System	Non-Vacuum	
工具重量	Net Weight	2.07 lbs (0.94 Kgs)	
包裝	Packing	5": 12 Pcs/15.84 Kg/16.9 Kg/2.4' 6": 12 Pcs/16.56 Kg/17.62 Kg/2.4'	



## AS090BNV5

### 隨機軌道砂光機 (9.0mm) Random Orbital Sander

## AS090BNV6

產品編號	Item Number	AS090BNV5	AS090BNV6
底盤尺寸	Pad Size	5" Pad	6" Pad
偏擺軌道	Diameter Orbit	9.0mm	
主軸螺紋	Spindle	5/16"-24 UNF	
耗氣量	Avg/ Air Con.	2.5 CFM	
進氣接頭	Air Inlet	1/4" NPT	
進氣壓力	Air Pressure	90 PSI (6.2 BAR)	
空轉轉速	Free Speed	10,000 RPM	
噪音值	Sound Pressure	83 DbA	
集塵系統	Dust System	Non-Vacuum	
工具重量	Net Weight	0.83 Kgs	
包裝	Packing	12 Pcs/14.5Kg/15.7Kg/2.8'	



## AS025BNV5

### 隨機軌道砂光機 (2.5mm) Random Orbital Sander

## AS025BNV6

產品編號	Item Number	AS025BNV5	AS025BNV6
底盤尺寸	Pad Size	5" Pad	6" Pad
偏擺軌道	Diameter Orbit	2.5mm	
主軸螺紋	Spindle	5/16"-24 UNF	
耗氣量	Avg/ Air Con.	2.5 CFM	
進氣接頭	Air Inlet	1/4" NPT	
進氣壓力	Air Pressure	90 PSI (6.2 BAR)	
空轉轉速	Free Speed	12,000 RPM	
噪音值	Sound Pressure	83 DbA	
集塵系統	Dust System	Non-Vacuum	
工具重量	Net Weight	0.83 Kgs	
包裝	Packing	12 Pcs/14.5Kg/15.7Kg/2.8'	



## AS050BNV5

### 隨機軌道砂光機 (5.0mm) Random Orbital Sander

## AS050BNV6

產品編號	Item Number	AS050BNV5	AS050BNV6
底盤尺寸	Pad Size	5" Pad	6" Pad
偏擺軌道	Diameter Orbit	5.0mm	
主軸螺紋	Spindle	5/16"-24 UNF	
耗氣量	Avg/ Air Con.	2.5 CFM	
進氣接頭	Air Inlet	1/4" NPT	
進氣壓力	Air Pressure	90 PSI (6.2 BAR)	
空轉轉速	Free Speed	12,000 RPM	
噪音值	Sound Pressure	83 DbA	
集塵系統	Dust System	Non-Vacuum	
工具重量	Net Weight	0.83 Kgs	
包裝	Packing	12 Pcs/14.5Kg/15.7Kg/2.8'	



## ASP010101

### 氣動噴漆槍 Air Spray Gun



標準噴嘴尺寸	Fluid Size(I.D.) mm	: 1.3
選配噴嘴尺寸	Optional Nozzle Size (mm)	: 1.0/1.5/1.8
耗氣量	Air Con. (1/min)	: 210-250 CFM
氣筒容量	Cup of Capacity	: 600 c.c
進氣接頭	Air Inlet	: 1/4" NPS
噴嘴接頭	Fluid Inlet	: 1/4" NPS
工作壓力	Working Pressure	: 28.0-36.0 PSI
工具重量	Net Weight	: 570g
型式	Type	: Suction

## ASP010201

### 氣動噴漆槍 Air Spray Gun



標準噴嘴尺寸	Fluid Size(I.D.) mm	: 1.6
選配噴嘴尺寸	Optional Nozzle Size (mm)	: 1.0/1.5/1.8/2.0
耗氣量	Air Con. (1/min)	: 280-360 CFM
氣筒容量	Cup of Capacity	: 1000c.c
進氣接頭	Air Inlet	: 1/4"
噴嘴接頭	Fluid Inlet	: 3/8"
工作壓力	Working Pressure	: 50.0-70.0 PSI
工具重量	Net Weight	: 1100g
型式	Type	: Suction

## ASP007101

### 氣動噴漆槍 Air Spray Gun



標準噴嘴尺寸	Fluid Size(I.D.) mm	: 1.5
選配噴嘴尺寸	Optional Nozzle Size (mm)	: 1.0/1.3/1.8/2.0
耗氣量	Air Con. (1/min)	: 180-230 CFM
氣筒容量	Cup of Capacity	: 700c.c
進氣接頭	Air Inlet	: 1/4"
噴嘴接頭	Fluid Inlet	: 1/4"
工作壓力	Working Pressure	: 43.0-50.0 PSI
工具重量	Net Weight	: 750g
型式	Type	: Suction

## ASP007701

### 氣動噴漆槍 Air Spray Gun



標準噴嘴尺寸	Fluid Size(I.D.) mm	: 2.0
選配噴嘴尺寸	Optional Nozzle Size (mm)	: 1.5/2.5
耗氣量	Air Con. (1/min)	: 250 CFM
氣筒容量	Cup of Capacity	: 1000c.c
進氣接頭	Air Inlet	: 1/4"
噴嘴接頭	Fluid Inlet	: 1/4"
工作壓力	Working Pressure	: 50.0 PSI
工具重量	Net Weight	: 950g
型式	Type	: Suction

## ASP020001

### 氣動噴漆槍 Air Spray Gun



標準噴嘴尺寸	Fluid Size(I.D.) mm	: 2.0
選配噴嘴尺寸	Optional Nozzle Size (mm)	: 1.2/1.4/1.5 1.6/1.8/2.5
耗氣量	Air Con. (1/min)	: 360 CFM
氣筒容量	Cup of Capacity	: 780 c.c
進氣接頭	Air Inlet	: 1/4"
噴嘴接頭	Fluid Inlet	: 3/8"
工作壓力	Working Pressure	: 4.3 PSI
工具重量	Net Weight	: 780g
型式	Type	: Suction

## AP501AKS4

### 氣動噴漆槍 Air Spray Gun



標準噴嘴尺寸	Fluid Size(I.D.) mm	: 1.4
選配噴嘴尺寸	Optional Nozzle Size (mm)	: 0.8/1.1/1.3/1.5 /1.8/2.0/2.5
流體出力	Fluid Output (c.c/min)	: 170
噴幅寬度	Pattern Width (mm)	: 255
耗氣量	Air Con. (1/min)	: 190
氣筒容量	Cup of Capacity	: 700 c.c/ 1000 c.c
進氣接頭	Air Inlet	: 1/4" PS
噴嘴接頭	Fluid Inlet	: 1/4" PS / 3/8" PS
工作壓力	Working Pressure	: 30-45 PSI
工具重量	Net Weight	: -
型式	Type	: Suction

AO080AGP  
AW050H  
New Air  
Impact Wrench  
Air Impact  
Wrench  
Screwdriver  
Air Ratchet  
Wrench  
Air  
Die Grinder  
Air Angle  
Grinder Series  
Air Sander  
Air Spray Gun  
Air Blow Gun  
Air Reverter  
Rivet Nut Tool  
Window Torque  
Wrench Series  
Patented  
Hand Tool Set

## ASP010102

### 氣動噴漆槍 Air Spray Gun



標準噴嘴尺寸	Fluid Size(I.D.) mm	: 1.3
選配噴嘴尺寸	Optional Nozzie Size (mm)	: 1.0/1.5/1.8
耗氣量	Air Con. (1/min)	: 210-250 CFM
氣筒容量	Cup of Capacity	: 400 c.c
進氣接頭	Air Inlet	: 1/4"
噴嘴接頭	Fluid Inlet	: 1/4"
工作壓力	Working Pressure	: 28.0-36.0 PSI
工具重量	Net Weight	: 460g
型式	Type	: Gravity

## ASP007102

### 氣動噴漆槍 Air Spray Gun



標準噴嘴尺寸	Fluid Size(I.D.) mm	: 1.5
選配噴嘴尺寸	Optional Nozzie Size (mm)	: 1.0/1.3/1.8/2.0
耗氣量	Air Con. (1/min)	: 180-230 CFM
氣筒容量	Cup of Capacity	: 300 c.c
進氣接頭	Air Inlet	: 1/4"
噴嘴接頭	Fluid Inlet	: 1/4"
工作壓力	Working Pressure	: 43.0-50.0 PSI
工具重量	Net Weight	: 600g
型式	Type	: Gravity

## ASP007702

### 氣動噴漆槍 Air Spray Gun



標準噴嘴尺寸	Fluid Size(I.D.) mm	: 2.0
選配噴嘴尺寸	Optional Nozzie Size (mm)	: 1.5/2.5
耗氣量	Air Con. (1/min)	: 250 CFM
氣筒容量	Cup of Capacity	: 400 c.c
進氣接頭	Air Inlet	: 1/4"
噴嘴接頭	Fluid Inlet	: 1/4"
工作壓力	Working Pressure	: 50.0 PSI
工具重量	Net Weight	: 700g
型式	Type	: Gravity

## ASP020002

### 氣動噴漆槍 Air Spray Gun



標準噴嘴尺寸	Fluid Size(I.D.) mm	: 2.0
選配噴嘴尺寸	Optional Nozzie Size (mm)	: 1.2/1.4/1.5 1.6/1.8/2.5
耗氣量	Air Con. (1/min)	: 360 CFM
氣筒容量	Cup of Capacity	: 400 c.c
進氣接頭	Air Inlet	: 1/4"
噴嘴接頭	Fluid Inlet	: 3/8"
工作壓力	Working Pressure	: 4.3 PSI
工具重量	Net Weight	: 620g
型式	Type	: Gravity

## AP607AKG5

### 氣動噴漆槍 Air Spray Gun



標準噴嘴尺寸	Fluid Size(I.D.) mm	: 1.5
選配噴嘴尺寸	Optional Nozzie Size (mm)	: 0.8/1.0/1.3 1.8/2.0
流體出力	Fluid Output (c.c/min)	: 210
噴幅寬度	Pattern Width (mm)	: 280
耗氣量	Air Con. (1/min)	: 220
氣筒容量	Cup of Capacity	: 250 / 400 c.c
進氣接頭	Air Inlet	: 1/4" PS
噴嘴接頭	Fluid Inlet	: 1/4" PS
工作壓力	Working Pressure	: 30-45 PSI
工具重量	Net Weight	: 280g
型式	Type	: Gravity

## AP808ARM3

### 氣動噴漆槍 Air Spray Gun



標準噴嘴尺寸	Fluid Size(I.D.) mm	: 1.3
選配噴嘴尺寸	Optional Nozzie Size (mm)	: 1.4/1.5/1.7 1.9/2.1/2.5
流體出力	Fluid Output (c.c/min)	: 228
噴幅寬度	Pattern Width (mm)	: 300
耗氣量	Air Con. (1/min)	: 305
氣筒容量	Cup of Capacity	: 600 c.c
進氣接頭	Air Inlet	: 1/4" PS
噴嘴接頭	Fluid Inlet	: M16 x 1.5P
工作壓力	Working Pressure	: 35 PSI
工具重量	Net Weight	: 450g
型式	Type	: Gravity



## AP808AHM3

### 氣動噴漆槍 Air Spray Gun



標準噴嘴尺寸	Fluid Size(I.D.) mm	: 1.3
選配噴嘴尺寸	Optional Nozzie Size (mm)	: 1.4/1.5/1.7 1.9/2.1/2.5
流體出力	Fluid Output (c.c/min)	: 120
噴幅寬度	Pattern Width (mm)	: 330
耗氣量	Air Con. (l/min)	: 300
氣筒容量	Cup of Capacity	: 600 c.c
進氣接頭	Air Inlet	: 1/4" PS
噴嘴接頭	Fluid Inlet	: M16 x 1.5P
工作壓力	Working Pressure	: 15-28 PSI
工具重量	Net Weight	: 450g
型式	Type	: Gravity

## AP410AHG4

### 氣動噴漆槍 Air Spray Gun



標準噴嘴尺寸	Fluid Size(I.D.) mm	: 1.4
選配噴嘴尺寸	Optional Nozzie Size (mm)	: 1.0/1.2/1.3/1.5 1.6/1.8/2.0/2.5
流體出力	Fluid Output (c.c/min)	: 213
噴幅寬度	Pattern Width (mm)	: 310
耗氣量	Air Con. (l/min)	: 310
氣筒容量	Cup of Capacity	: 600 c.c
進氣接頭	Air Inlet	: 1/4" PS
噴嘴接頭	Fluid Inlet	: M16 x 1.5P
工作壓力	Working Pressure	: 15-28 PSI
工具重量	Net Weight	: 497g
型式	Type	: Gravity

## AP410AKG4

### 氣動噴漆槍 Air Spray Gun



標準噴嘴尺寸	Fluid Size(I.D.) mm	: 1.4
選配噴嘴尺寸	Optional Nozzie Size (mm)	: 1.0/1.2/1.3/1.5 1.6/1.8/2.0/2.5
流體出力	Fluid Output (c.c/min)	: 265
噴幅寬度	Pattern Width (mm)	: 300
耗氣量	Air Con. (l/min)	: 280
氣筒容量	Cup of Capacity	: 600 c.c
進氣接頭	Air Inlet	: 1/4" PS
噴嘴接頭	Fluid Inlet	: M16 x 1.5P
工作壓力	Working Pressure	: 20-35 PSI
工具重量	Net Weight	: 497g
型式	Type	: Gravity

## ASP220001

### 氣動噴漆槍 Air Spray Gun



標準噴嘴尺寸	Fluid Size(I.D.) mm	: 1.3
選配噴嘴尺寸	Optional Nozzie Size (mm)	: 1.2/1.4
耗氣量	Air Con. (l/min)	: 275 CFM
氣筒容量	Cup of Capacity	: 600 c.c
進氣接頭	Air Inlet	: 1/4"
噴嘴接頭	Fluid Inlet	: 3/8"
工作壓力	Working Pressure	: 29.0 PSI
工具重量	Net Weight	: 650g
型式	Type	: High Efficiency Gravity

## ASP220002

### 氣動噴漆槍 Air Spray Gun

HVLP-Gravity



標準噴嘴尺寸	Fluid Size(I.D.) mm	: 1.3
選配噴嘴尺寸	Optional Nozzie Size (mm)	: 1.2/1.4
耗氣量	Air Con. (l/min)	: 465 CFM
氣筒容量	Cup of Capacity	: 600 c.c
進氣接頭	Air Inlet	: 1/4"
噴嘴接頭	Fluid Inlet	: 3/8"
工作壓力	Working Pressure	: 1.8 Kg/cm
工具重量	Net Weight	: 650g
型式	Type	: HVLP-Gravity

## ASP000501

### 氣動噴漆槍 Air Spray Gun

HVLP Touch-up



標準噴嘴尺寸	Fluid Size(I.D.) mm	: 1.0
選配噴嘴尺寸	Optional Nozzie Size (mm)	: 0.5/0.8/1.0/1.2/1.4
耗氣量	Air Con. (l/min)	: 115 CFM
氣筒容量	Cup of Capacity	: 125 c.c
進氣接頭	Air Inlet	: 1/4"
噴嘴接頭	Fluid Inlet	: M10 x 1.0
工作壓力	Working Pressure	: 29.0 PSI
工具重量	Net Weight	: 320g
型式	Type	: HVLP Touch-up

## ABG001-041

### 氣動吹塵槍 Air Blow Gun



噴嘴長度	Nozzle length	: 4"
噴嘴尺寸	Nozzle size	: 6 mm
工作壓力	Max working pressure	: 120 psi
進氣壓力	Max air pressure	: 130psi
進氣內徑	Brass inlet thread	: 1/4" PT

Customized color & Logo printing design available  
客製化服務: 顏色 & 商標

## ABG001-101

### 氣動吹塵槍 Air Blow Gun



噴嘴長度	Nozzle length	: 10"
噴嘴尺寸	Nozzle size	: 6 mm
工作壓力	Max working pressure	: 120 psi
進氣壓力	Max air pressure	: 130psi
進氣內徑	Brass inlet thread	: 1/4" PT

Customized color & Logo printing design available  
客製化服務: 顏色 & 商標



ABG-002SF  
(Fit with safety nozzle)

## ABG002-041

### 氣動吹塵槍 Air Blow Gun



## ABG002-101

### 氣動吹塵槍 Air Blow Gun



## ABG002-131

### 氣動吹塵槍 Air Blow Gun



## ABG002-201

### 氣動吹塵槍 Air Blow Gun



產品編號 Item Number	噴嘴長度 Nozzle Length	噴嘴尺寸 Nozzle Size	工作壓力 Max Working Pressure	進氣壓力 Max Air Pressure	進氣內徑 Brass Inlet Thread	包裝 Packing
AB5002-041	4"	8 mm	120 psi	200 psi	1/4" (PT, NPT, BSP)	100 Pcs/17.0 Kgs/18.0 Kgs/3.5'
AB5002-101	10"	8 mm	120 psi	200 psi	1/4" (PT, NPT, BSP)	50 Pcs/12.0 Kgs/13.0 Kgs/2.76'
AB5002-131	13"	8 mm	120 psi	200 psi	1/4" (PT, NPT, BSP)	50 Pcs/13.0 Kgs/14.0 Kgs/3.06'
AB5002-201	20"	8 mm	120 psi	200 psi	1/4" (PT, NPT, BSP)	50 Pcs/16.0 Kgs/17.0 Kgs/4.22'

## AV248A14

### 氣動液壓鉚釘機 Air Hydraulic Riveter

進氣接頭	Air Inlet	: 1/4"
風管內徑	Hose Size I.D.	: 3/8"
耗氣量	Avg/ Air Con.	: 3.5 CFM (99 L/min)
工作拉力	Traction Power	: 2680 LBS / 1219 Kgs
行程長度	Stroke Length	: 14 mm
工作壓力	Working Pressure	: 80-100 PSI
鉚釘	Blind Rivet Setting	: 3/32"-3/16"
設置尺寸	Capacity-mm	(2.4-4.8 mm)
最大鉚接	Max Rivet	: AL. & Steel: 4.8 mm
尺寸	Capacity	Stainless: 4 mm
鉚釘材質	Rivet Material	: Aluminum/Steel/Stainless
工具重量	Net Weight	: 1.5 Kgs (3.3 LBS)



## AN312A06

### 氣動液壓拉帽機 Air Hydraulic Rivet Nut Tools

進氣接頭	Air Inlet	: 1/4"
風管內徑	Hose Size I.D.	: 3/8"
耗氣量	Avg/ Air Con.	: 1.12 CFM (31.8 L/min)
工作拉力	Traction Power	: 4565 LBS / 2075 Kgs
行程長度	Stroke Length	: 6 mm
工作壓力	Working Pressure	: 80-100 PSI
鉚螺母	Rivet Nut Setting	: M3, M4, M5, M6
設置尺寸	Capacity-mm	M8, M10, M12
最大鉚接	Max Rivet Nut	: AL. & Steel: M12
尺寸	Capacity	Stainless: M10
鉚釘材質	Rivet Material	: Aluminum/Steel/Stainless
工具重量	Net Weight	: 2.38 Kgs (5.24 LBS)



## AV264A19

### 氣動液壓鉚釘機 Air Hydraulic Riveter

進氣接頭	Air Inlet	: 1/4"
風管內徑	Hose Size I.D.	: 3/8"
耗氣量	Avg/ Air Con.	: 4.2 CFM (119 L/min)
工作拉力	Traction Power	: 4166 LBS / 1894 Kgs
行程長度	Stroke Length	: 19 mm
工作壓力	Working Pressure	: 80-100 PSI
鉚釘	Blind Rivet Setting	: 3/32"-1/4"
設置尺寸	Capacity-mm	(2.4-6.4 mm)
最大鉚接	Max Rivet	: AL. & Steel : 6.4 mm
尺寸	Capacity	Stainless : 5.6 mm
鉚釘材質	Rivet Material	: Aluminum/Steel/Stainless
工具重量	Net Weight	: 2.0 Kgs (4.3 LBS)



## AN410A13

### 氣動液壓拉帽機 Air Hydraulic Rivet Nut Tools

進氣接頭	Air Inlet	: 1/4"
風管內徑	Hose Size I.D.	: 3/8"
耗氣量	Avg/ Air Con.	: 3.0 CFM (105 L/min)
工作拉力	Traction Power	: 2680 LBS / 1219 Kgs
行程長度	Stroke Length	: 6.5 mm
工作壓力	Working Pressure	: 58-95 PSI*
鉚螺母	Rivet Nut Setting	: M4, M5, M6,
設置尺寸	Capacity-mm	M8, M10
最大鉚接	Max Rivet Nut	: AL. & Steel : M10
尺寸	Capacity	Stainless : M6
鉚釘材質	Rivet Material	: Aluminum/Steel/Stainless
工具重量	Net Weight	: 1.63 Kgs (3.59 LBS)



\* M4, M5: 58-65 PSI ; M6: 80-85 PSI ; M8, M10: 90-95 PSI

## BREAKBACK

### 折彎式扭力扳手 Window Torque Wrench

- Push-through ratchet allows two direction tightening.
- Tolerance of torque  $\pm 4\%$ .
- Quality meets DIN ISO 6789 & ASME B107.300-2010.



Split and packed in two parts.

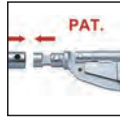

Renewal Kit

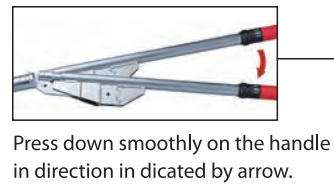

Item Number	Square Drive	Teeth	Nm/ft-lb	Graduation	g	L(mm)	case /CTN
ATW0601-34	3/4"	36T	120-600/100-450	10	6600	1060	2
ATW0602-34	3/4"	36T	200-800/150-600	10	7900	1320	1
ATW0603-34	3/4"	36T	300-1000/200-750	20	8060	1550	1
ATW0604-10	1"	36T	120-600/100-450	10	6600	1060	2
ATW0605-10	1"	36T	200-800/150-600	10	7900	1320	1
ATW0606-10	1"	36T	300-1000/200-750	20	8060	1550	1

## NUMERIC

### 視窗型扭力扳手 Window Torque Wrench

- Tolerance of torque  $\pm 3\%$ .
- CW/CCW direction.
- Quality meets DIN ISO 6789 & ASME B107.300-2010.



Quick released design.

LED lights inside.

Pull out knob for adjustment.

Item Number	Square Drive	Teeth	Nm	lbf.ft	Graduation	g	L(mm)	case /CTN
ATW0001-14	1/4"	24T	4-20	3-14.8	0.1	800	368	24
ATW0002-38	3/8"	24T	4-20	3-14.8	0.1	800	368	24
ATW0003-38	3/8"	32T	20-100	15-74	0.5	1200	435	12
ATW0004-12	1/2"	32T	40-200	30-148	1	1470	510	12
ATW0005-12	1/2"	32T	60-340	44-251	2	1670	615	12

Red push button for LED light; click once again to close. 12V battery is required.

## SPLIT-BEAM

### 彈力式扭力扳手 Window Torque Wrench

- Torque of tolerance: unflexed  $\pm 4\%$ ; flexed  $\pm 4\sim \pm 10\%$ .
- Non coil-spring mechanism and no need to return to zero after use, which brings longer tool life.



Renewal Kit

Open the hinge cover, adjust setting by knob (PAT.)

Setting display in window

Item Number	Square Drive	Teeth	Swing arc	Nm	ft-lb	Graduation	g	L(mm)	case /CTN
ATW1101-38	3/8"	32T	15	25-130	-	5	950	475	12
ATW1102-12	1/2"	32T	15	70-350	-	5	1705	590	12
ATW1103-38	3/8"	32T	15	-	20-100	2	950	475	12
ATW1104-12	1/2"	32T	15	-	40-250	5	1705	590	12

## ROBUST

### G型視窗型扭力扳手 Window Torque Wrench

- Adjustable torque wrench with square drive for controlled tightening
- Tolerance of torque  $\pm 4\%$ .
- Quality meets DIN ISO 6789 & ASME B107.300-2010.



Reliable mechanism: Loud click sound and strong impulse when required torque is reached.

Dual scale below window.

- Turn to left.
- Adjust the torque.
- Turn to right and lock.

Item Number	Square Drive	Teeth	Nm	lbf.ft	Graduation	g	L(mm)	case /CTN
ATW0501-14	1/4"	24T	5-25	3.6-18	0.1	410	296	24
ATW0502-38	3/8"	24T	10-50	7.4-37	0.25	470	333	12
ATW0503-12	1/2"	32T	20-100	15-75	0.5	820	400	12
ATW0504-12	1/2"	32T	40-200	30-150	1	1300	500	12
ATW0505-12	1/2"	32T	60-300	45-220	1	1470	635	12
ATW0506-34	3/4"	24T	100-600	75-440	2	4560	1040	2
ATW0507-34	3/4"	24T	150-800	110-590	5	5192	1161	2
ATW0508-34	3/4"	24T	200-1000	150-740	5	5192	1161	2



Renewal Kit

## SLIPPING

### 空轉式扭力扳手 Window Torque Wrench

- Unique continuous slipping mechanism eliminates the risk of over tightening.
- Tolerance of torque  $\pm 6\%$ . (1-5NM, 2-10NM)
- Tolerance of torque  $\pm 4\%$ . (5-25NM, 10-60NM, 20-100NM)
- Quality meets DIN ISO 6789 & ASME B107.300-2010.



Slipping Mechanism: When the torque value is achieved, the mechanism slips through over the roller and automatic resetting.

Dual scale below window.

- Turn to left.
- Adjust the torque.
- Turn to right and lock.

Item Number	Square Drive	Teeth	Nm	lbf.ft	Graduation	g	L(mm)	case /CTN
ATW0201-14	1/4"	36T	1-5	0.7-3.7	0.05	520	260	24
ATW0202-14	1/4"	36T	2-10	1.5-7.4	0.1	520	260	24
ATW0203-14	1/4"	36T	5-25	3.5-18	0.1	590	320	24
ATW0204-38	3/8"	36T	5-25	3.5-18	0.1	590	320	24
ATW0205-38	3/8"	48T	10-60	8-44	0.25	655	355	24
ATW0206-38	3/8"	48T	25-100	18-75	0.5	1430	475	12
ATW0207-12	1/2"	48T	10-60	8-44	0.25	655	355	24
ATW0208-12	1/2"	48T	25-100	18-75	0.5	1430	475	12
ATW0209-14	1/4"	36T	2-10	20-90 (in-lb)	0.1	520	260	24



Renewal Kit

AO080ACGP  
AW050H  
New Air  
Impact Wrench  
Air Impact  
Wrench  
Air  
Screwdriver  
Air Ratchet  
Wrench  
Air  
Die Grinder  
Air  
Grinder Series  
Air Sander  
Air Spray Gun  
Air Blow Gun  
Air Reverser  
Rivet Nut Tool  
Window Torque  
Wrench Series  
Patented  
Hand Tool Set



## 24PCS 22H(1/2"DR.)

### APACH INSERT-SNAP WRENCH & SUPER SHORT SOCKET SET

#### AH024A114

- 1Pc 22H Apach Insert-Snap Wrench
- 2Pcs 1/2"Dr. Extension Bar : 5", 10"
- 1Pc 22H x 1/2"Dr. Quick Release Socket Adaptor
- 1Pc 1/2"Dr. Universal Joint
- 19Pcs 22H(1/2"Dr.) 2 Way Super Short Socket: 8, 9, 10, 11, 12, 13, 14, 15, 16, 17, 18, 19, 20, 21, 22, 24, 27, 30, 32mm
- Packing : 6 Set/21.1 Kg/21.8 Kg/1.7'

#### AH024A114A

- 1Pc 22H Apach Insert-Snap Wrench
- 2Pcs 1/2"Dr. Extension Bar : 5", 10"
- 1Pc 22H x 1/2"Dr. Quick Release Socket Adaptor
- 1Pc 1/2"Dr. Universal Joint
- 19Pcs 22H(1/2"Dr.) 2 Way Super Short Socket: 5/16", 11/32", 3/8", 7/16", 15/32", 1/2", 9/16", 19/32", 5/8", 11/16", 3/4", 25/32", 13/16", 7/8", 15/16", 1" 1-1/16", 1-3/16", 1-1/4"
- Packing : 6 Set/21.1 Kg/21.8 Kg/1.7'



## 18PCS 17H(3/8"DR.)

### APACH INSERT-SNAP WRENCH & SUPER SHORT SOCKET SET

#### AH018B113

- 1Pc 17H Apach Insert-Snap Wrench
- 2Pcs 3/8"Dr. Extension Bar 3", 6"
- 1Pc 17H x 3/8"Dr. Quick Release Socket Adaptor
- 1Pc 3/8"Dr. Universal Joint
- 13Pcs 17H(3/8"Dr.) 2 Way Super Short Socket: 8, 9, 10, 11, 12, 13, 14, 15, 16, 17, 19, 21, 22mm
- Packing : 6 Set/10.5 Kg/11.5 Kg/0.41'

#### AH018B113A

- 1Pc 17H Apach Insert-Snap Wrench
- 2Pcs 3/8"Dr. Extension Bar 3", 6"
- 1Pc 17H x 3/8"Dr. Quick Release Socket Adaptor
- 1Pc 3/8"Dr. Universal Joint
- 13Pcs 17H(3/8"Dr.) 2 Way Super Short Socket: 5/16", 11/32", 3/8", 7/16", 15/32", 1/2", 9/16", 19/32", 5/8", 11/16", 3/4", 13/16", 7/8"
- Packing : 6 Set/10.5 Kg/11.5 Kg/0.41'



## 18PCS 17H(3/8"DR.)

### APACH INSERT-SNAP WRENCH & SUPER SHORT SOCKET SET (MM/S.A.E)

#### AH018A113

- 1Pc 17H Apach Insert-Snap Wrench
- 2Pcs 3/8"Dr. Extension Bar 3", 6"
- 1Pc 17H x 3/8"Dr. Quick Release Socket Adaptor
- 1Pc 3/8"Dr. Universal Joint
- 13Pcs 17H(3/8"Dr.) 2 Way Super Short Socket: 8, 9, 10, 11, 12, 13, 14, 15, 16, 17, 19, 21, 22mm
- Packing : 12 Set/16 Kg/17 Kg/1.4'

#### AH018A113A

- 1Pc 17H Apach Insert-Snap Wrench
- 2Pcs 3/8"Dr. Extension Bar 3", 6"
- 1Pc 17H x 3/8"Dr. Quick Release Socket Adaptor
- 1Pc 3/8"Dr. Universal Joint
- 13Pcs 17H(3/8"Dr.) 2 Way Super Short Socket: 5/16", 11/32", 3/8", 7/16", 15/32", 1/2", 9/16", 19/32", 5/8", 11/16", 3/4", 13/16", 7/8"
- Packing : 12 Set/16 Kg/17 Kg/1.4'



## 22PCS 22H(1/2"DR.)

### APACH INSERT-SNAP WRENCH & SUPER SHORT SOCKET SET

#### AH022A114

- 1Pc 22H Apach Insert-Snap Wrench
- 2Pcs 1/2"Dr. Extension Bar : 5", 10"
- 1Pc 1/2"Dr. Universal Joint
- 1Pc 22H x 1/2"Dr. Quick Release Socket Adaptor
- 17Pcs 22H(1/2"Dr.) 2 Way Super Short Socket: 8, 9, 10, 11, 12, 13, 14, 15, 16, 17, 19, 21, 22, 24, 27, 30, 32mm
- Packing : 6 Set/23.5 Kg/24.5 Kg/1.2'



## 31PCS 17H(3/8"DR.)

### APACH INSERT-SNAP WRENCH & SUPER SHORT SOCKET SET (MM/S.A.E)

#### AH031A113

- 11Pc 17H Apach Insert-Snap Wrench
- 1Pc 17H x 3/8"Dr. Quick Release Socket Adaptor
- 2Pcs 3/8"Dr. Extension Bar 3", 6"
- 1Pc 3/8"Dr.(M) x 1/4"Dr.(F) 3 Way Adaptor
- 1Pc 3/8"Dr. Universal Joint
- 13Pcs 17H(3/8"Dr.) 2 Way Super Short Socket: 8, 9, 10, 11, 12, 13, 14, 15, 16, 17, 19, 21, 22mm
- 1Pc 17H x 1/4"Dr. Quick Release Socket Adaptor
- 2Pcs 1/4"Dr. Extension Bar 2", 6"
- 9Pcs 1/4"Dr. Socket: 4, 4.5, 5, 5.5, 6, 7, 8, 9, 10mm
- Packing : 12 Set/18.5 Kg/19.5 Kg/1.4'

#### AH031A113A

- 1Pc 17H Apach Insert-Snap Wrench
- 1Pc 17H x 3/8"Dr. Quick Release Socket Adaptor
- 2Pcs 3/8"Dr. Extension Bar 3", 6"
- 1Pc 3/8"Dr.(M) x 1/4"Dr.(F) 3 Way Adaptor
- 1Pc 3/8"Dr. Universal Joint
- 13Pcs 17H(3/8"Dr.) 2 Way Super Short Socket: 5/16", 11/32", 3/8", 7/16", 15/32", 1/2", 9/16", 19/32", 5/8", 11/16", 3/4", 13/16", 7/8"
- 1Pc 17H x 1/4"Dr. Quick Release Socket Adaptor
- 2Pcs 1/4"Dr. Extension Bar 2", 6"
- 9Pcs 1/4"Dr. Socket: 5/32", 3/16", 7/32", 1/4", 9/32", 5/16", 11/32", 3/8", 7/16"
- Packing : 12 Set/18.5 Kg/19.5 Kg/1.4'



## 43PCS 1/4"DR. & 3/8"

### APACH 17H INSERT-SNAP WRENCH & SUPER SHORT SOCKET SET

#### AH043A121

- 1Pc 17H Apach Insert-Snap Wrench
- 2Pcs Quick Release Adaptor : 17H x 1/4"Dr. & 17H x 3/8"Dr.
- 1Pc 17H x 3/8"Dr. Universal Joint
- 2Pcs 17H x 3/8"Dr. Ext. Bar 3" & 6"
- 13Pcs 17H x 3/8"Dr. Super Short Socket mm Size: 8, 9, 10, 11, 12, 13, 14, 15, 16, 17, 19, 21, 22
- 13Pcs 17H x 3/8"Dr. Super Short Socket AF Size: 5/16", 11/32", 3/8", 7/16", 15/32", 1/2", 9/16", 19/32", 5/8", 11/16", 3/4", 13/16", 7/8"
- 2Pcs 1/4"Dr. Ext. Bar : 2" & 6"
- 9Pcs 1/4"Dr. All Size Super Short Socket: 4, 4.5, 5, 5.5, 6, 7, 8, 9, 10mm
- Packing : 6 Set/18 Kg/19 Kg/1.2'





## 27PCS

### APACH INSERT-SNAP WRENCH & BIT SET

#### AH027A222

- 1Pc 11H Apach Insert-Snap Wrench
- 1Pc 1/4"Dr. x 11mm Hex Extension Bar: 2"
- 13Pcs 1/4"Dr. x 11mm Hex Super Short Multi Lock Socket:
- 4, 4.5, 5, 5.5, 6, 7, 8, 9, 10, 11, 12, 13, 14mm
- 12Pcs 1/4" Hex Shank Bits x 25mmL:
  - PH: 1, 2 ; SL: 4, 5, 6 ; T: 10, 15, 20, 25, 27, 30, 40
- Packing : 40 Set/18.5 Kg/19 Kg/2.4'



## 13PCS 17H(3/8"DR.)

### SUPER SHORT SOCKET SET

#### AH013A103

- 13Pcs 17H(3/8"Dr.) 2 Way Super Short Socket: 8, 9, 10, 11, 12, 13, 14, 15, 16, 17, 19, 21, 22mm
- Packing : 40 Set/20 Kg/21 Kg/0.8'

#### AH013A103A

- 13Pcs 17H(3/8"Dr.) 2 Way Super Short Socket: 5/16", 11/32", 3/8", 7/16", 15/32", 1/2", 9/16", 19/32", 5/8", 11/16", 3/4", 13/16", 7/8"
- Packing : 40 Set/20 Kg/21 Kg/0.8'



## 76PCS 11(1/4"DR.)

### APACH INSERT-SNAP WRENCH & SUPER SHORT SOCKET (MULTI LOCK) SET

#### AH8021763

- 1Pc 11H Apach Insert-Snap Wrench
- 1Pc 11H x 1/4"Dr. Extension Bar
- 13Pcs 11H x 1/4"Dr. Super Short Multi Lock Socket :
- 4, 4.5, 5, 5.5, 6, 7, 8, 9, 10, 11, 12, 13, 14mm
- 1Pc 1/4"Hex x 60mmL Bit Holder
- 60Pcs 1/4"Hex Shank Bits x 25mmL:
  - PH: 0, 1, 2, 2, 3, 4 ; PZ: 0, 1, 2, 2, 3, 4
  - SL: 3, 4, 4.5, 5, 5.5, 6, 6.5, 7, 8 ; Spline: M5, 6, 8
  - Hex: 2, 2.5, 3, 3.5, 4, 4.5, 5, 5.5, 6, 7, 8
  - Tx: 10, 15, 20, 25, 27, 30, 40, 45
  - Tx Tamper: 10, 15, 20, 25, 27, 30, 40, 45
  - Ts Tamper: 10, 15, 20, 25, 27, 30, 40, 45, 50
- Packing : 12 Set/12 Kg/13 Kg/1.4'



## 25PCS 1/4"DR.

### RATCHET MULTIPLE DEGREE WOBBLE RATCHET WRENCH & SUPER SHORT SOCKET SET

#### AH025B412

- 1Pc 1/4"Dr. Ratchet Multiple Degree Wobble Ratchet Wrench : Size: 1/4"Dr, Teeth: 90T, Length: 90L ; One side wobble degree is 105. Also available to work in deep places. Can be used like tradition ratchet wrench.
- 13Pcs 1/4"Dr. Super Short Sockets : 4, 4.5, 5, 5.5, 6, 7, 8, 9, 10, 11, 12, 13, 14mm
- 10Pcs Bits : Slot: 4, 5, 6 ; Phillips:1, 2 ; Tx-Star : T10, T15, T20, T25, T27
- 1Pc Bit Holder
- Material: CR-V
- Finish: Mirror Polish
- Packing : 40 Sets/15 Kg/16 Kg/1.02'



## 35PCS 1/4"DR.

### SUPER SHORT SOCKET & BIT SET

#### AH035A422

- 1 Pc 1/4"Hex x 1/4"Dr. Bit Ratchet Double End Wrench
- 1 Pc 1/4"Dr. Extension Bar x 50mmL
- 13 Pcs 1/4"Dr. Super Short Multi-Lock Socket: 4, 4.5, 5, 5.5, 6, 7, 8, 9, 10, 11, 12, 13, 14mm
- 20 Pcs 1/4"Hex Shank Bits x 25mmL: Hex: 2, 2.5, 3, 4, 5, 6 ; Slot: SL4, 5, 6 ; Phillips: PH0, 1, 2, 3 ; Torx: T10, T15, T20, T25, T27, T30, T40
- Material: CR-V / Bit: S2
- Finish: Sanding Mirror Chrome / Bit: Sanding
- Packing : 40 Sets/20 Kg/21 Kg/1.27'



## 25PCS 1/4"DR.

### APACH INSERT-SNAP WRENCH & SUPER SHORT SOCKET & BIT SET

#### AH025A412

- 1Pc 1/4"Dr. 72T Apach Insert-Snap Ratchet Wrench
- 1Pc 1/4"Dr. Bit Adaptor
- 10Pcs 1/4" Shank x 25mmL Bit : Slot : 4, 5, 6 ; Phillips : 1, 2 ; Tx-Star : T10, 15, 20, 25, 27
- 13Pcs 1/4"Dr. Super Short Socket x 19mmL : 4, 4.5, 5, 5.5, 6, 7, 8, 9, 10, 11, 12, 13, 14mm
- Packing : 20 Set/11 Kg/12 Kg/1.17'





## 40PCS 10 mm

### APACH INSERT-SNAP WRENCH & BIT SET

#### AH040A520

- 1Pc 2 Way 10mm Apach Insert-Snap Wrench
- 1Pc Extension Bar 75mmL
- 38Pcs 10mm Bit x 30mmL:
  - Torx : T10, 15, 20, 25, 27, 30, 40, 45, 50, 55
  - Torx Tamper : T10H, 15, 20, 25, 27, 30, 40, 45, 50, 55
  - Hex: H4, 5, 6, 7, 8, 10 ; Spline: M4, 5, 6, 8, 10, 12
  - Ribe: RM5, 6, 7, 8, 9, 10
- Packing : 10 Set/16.3 Kg/16.9 Kg/0.66'

#### AH040A520P

- 1Pc 2 Way 10mm Apach Insert-Snap Wrench
- 1Pc Extension Bar 75mmL
- 38Pcs 10mm Bit x 30mmL :
  - Torx : T10, 15, 20, 25, 27, 30, 40, 45, 50, 55
  - Torx Tamper : T10H, 15, 20, 25, 27, 30, 40, 45, 50, 55
  - Torx-Plus : IP10, 15, 20, 25, 27, 30, 40, 45, 50
  - Torx-Plus Tamper : IPR10, 15, 20, 25, 27, 30, 40, 45, 50
- Packing : 10 Set/16.3 Kg/16.9 Kg/0.66'



## 23PCS 17H(3/8"DR.)

### APACH INSERT-SNAP WRENCH & SUPER SHORT SOCKET SET

#### AH023A113

- 1Pc 17H Apach Insert-Snap Wrench
- 1Pc 3/8"Dr. Extension Bar 6"
- 1Pc 17H x 3/8"Dr. Quick Release Socket Adaptor
- 10Pcs 17H(3/8"Dr.) 2 Way Super Short Socket (Metric): 8, 10, 11, 12, 13, 14, 17, 19, 21, 22mm
- 10Pcs 17H(3/8"Dr.) 2 Way Super Short Socket (S.A.E): 5/16", 3/8", 7/16", 15/32", 1/2", 9/16", 11/16", 3/4", 13/16", 7/8"
- Packing : 12 Set/14.5 Kg/15.5 Kg/1.4'



## 4PCS 17H(3/8"DR.)

### APACH INSERT-SNAP WRENCH & QUICK-RELEASE ADAPTOR SET

#### AH004A611

- 1Pc 17H Apach Insert-Snap Wrench
- 1Pc 17H x 1/4"Dr. Quick Release Socket Adaptor
- 1Pc 17H x 3/8"Dr. Quick Release Socket Adaptor
- 1Pc 17H x 1/2"Dr. Quick Release Socket Adaptor
- Packing : 48 Set/18.5 Kg/19.5 Kg/1.5'



## 22H & 17H

### APACH INSERT-SNAP RATCHET HEAD

#### AH274

- 22H Apach Insert-Snap Ratchet Insert Head (Fixed)
- The Size Of End Fitting(mm): 14 x 18

#### AH273

- 17H Apach Insert-Snap Ratchet Insert Head (Fixed)
- The Size Of End Fitting(mm): 9 x 12



### CLUTCH-LOCK SOCKET

#### AK403014

- Even for worn-out screw, its user still could lose/lock the screw easily.
- The Clutch-Lock socket won't touch the angle of screw.
- Protect screw.
- Grip tightly.

Socket Picture	6PT Socket	12PT Socket	BigR Design Socket	Clutch-Lock Socket
Normal Screw	✓	✓	✓	✓
50% Worn-Out Screw	✗	✗	✓	✓
70% Worn-Out Screw	✗	✗	✗	✓ <b>WIN</b>



## HOSE REELS

風管

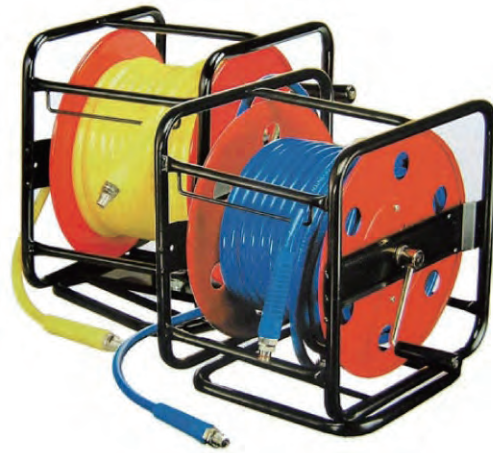

- Material : Polyurethane Braid Hose
- Maximum Working Pressure : 220 PSI / 15 BAR
- Working Temperature : -20° C to +60° C
- Features : 360° Rotary Base for High Efficiency

### ▲ Hose Reels

產品編號 Item Number	軟管尺寸 Hose Length		軟管長度 Hose Length	
	mm	Inch	mm	Inch
HR026530	6.5	1/4"	30	100
HR026550	6.5	1/4"	50	165
HR028020	8.0	5/16"	20	66
HR028030	8.0	5/16"	30	100
HR028040	8.0	5/16"	40	132
HR028520	8.5	11/32"	20	66
HR028530	8.5	11/32"	30	100
HR029520	9.5	3/8"	20	66
HR029530	9.5	3/8"	30	100
HR021020	10.0	13/32"	20	66

### ▲ Bulk Reels

產品編號 Item Number	軟管尺寸 Hose Size (ID x OD)	長度 Length (M)
PUB-065100	6.5 x 10 mm	10, 20, 30, 50, 100
PUB-080120	8 x 12 mm	10, 20, 30, 50, 100
PUB-085125	8.5 x 12.5 mm	10, 20, 30, 50, 100
PUB-100150	10 x 15 mm	10, 20, 30, 50, 100
PUB-110160	11 x 16 mm	10, 20, 30, 50, 100
PUB-130190	13 x 19 mm	10, 20, 30, 50, 100

All sizes of Re-coil Hose are also available.  
Contact our customer service for more information.

## AV140A40

氣壓調節器

### Air Pressure Regulator

Control stable air pressure from 40 PSI to 140 PSI.



Get More News of  
APACH's Latest Products

AO080AGP  
AW050H  
New Air  
Impact Wrench  
Air Impact  
Wrench  
Air  
Screwdriver  
Air Ratchet  
Wrench  
Air  
Die Grinder  
Air Angle  
Grinder Series  
Air Sander  
Air Spray Gun  
Air Blow Gun  
Air Reverter  
Nut Tool  
Window Torque  
Wrench Series  
Patented  
Hand Tool Set